

# CS4000 Mini Controller with Ethernet



Technical Reference Manual

**24-Hour  
Technical Support  
Toll Free:  
1-877-224-7377**

## Please Note:



has a new name. We are now



This change of name is not yet reflected in the documentation for this product where you will still find the old logo and company name. The new address is:

SPX GSE *tech-motive tool*  
42860 Nine Mile Road,  
Novi MI 48375-4122

The toll free service number remains the same: 1-877-224-7377.

## LIMITED WARRANTY

Except for perishable items, such as the fuses and batteries, SPX *GSE tech-motive tool* warrants its *GSE tech-motive tool* brand fastening products, *GSE* brand sensors and instruments, and fastening systems to be free from defects in materials and workmanship for one year from the date of shipment from the manufacturing facility.

The obligation of SPX *GSE tech-motive tool* is limited to repairing, or at their option, replacing the products and components which, upon verification at the manufacturing facility in Novi, Michigan USA, prove to be defective. SPX *GSE tech-motive tool* shall not be liable for installation charges, for expenses of the Buyer for repairs or replacement, for damages from delay or loss of use, or other indirect or consequential damages of any kind. SPX *GSE tech-motive tool* extends this warranty only upon proper use of the product in the application for which it is intended. The warranty does not cover products that have been modified without the approval of SPX *GSE tech-motive tool* or which have been subjected to unusual physical or electrical stress, or from or upon which the original identification marks have been removed or altered.

Whenever the design of the system in which it is to be incorporated originates with the Buyer, the warranty is limited specifically to furnishing the controllers and nutrunners free of defects in materials and workmanship and assumes no responsibility for implied warranties of fitness for purpose or use.

In the event that a product is repaired or replaced under the terms of the warranty, the warranty period of the repaired or replacement product shall be limited by the agreed upon level of warranty purchased by the customer.

Industrial installations are warranted by SPX *GSE tech-motive tool* for repairs at the installation site only if the customer contracts with SPX *GSE tech-motive tool* to perform checkout and final adjustment at the installation site and for the training of customer personnel in the operation and maintenance under the system. Under such conditions, SPX *GSE tech-motive tool* agrees to perform field service for 90 days from date of checkout without charge for labor or materials. The customer shall pay for travel expenses of SPX *GSE tech-motive tool* personnel.

Warranty of peripheral equipment, such as printers, recorders, plotters, etc., included with a *GSE tech-motive tool* or *GSE* torque product or SPX *GSE tech-motive tool* fastening system, shall be extended to the Buyer on the original manufacturer's terms.

Transportation charges for materials shipped to the manufacturing facility for warranty repair are to be paid by the shipper. SPX *GSE tech-motive tool* will return items repaired or replaced under warranty prepaid.

Information and technical diagrams in this document are subject to change without notice. Products and services referred to in this book may be either trademarks and/or registered trademarks of their respective owners.

SPX *GSE tech-motive tool* manufactures products under the *GSE* and *tech-motive tool*<sup>®</sup> brand names in Novi, MI.

© 2002 SPX CORPORATION. ALL RIGHTS RESERVED.

# Acknowledgments

Special thanks are extended to the following SPX *GSE tech-motive tool* management, software and hardware engineers who provided value information in the development and review of this manual.

Jim Grenier  
Tom Jozwiak  
Ken Lehoczky  
Larry Piggins  
Rick Szwas  
Steve Urbanski  
Bill Welch

Karen R. Francis, technical writer  
Linda J. Ashley, editor

# Preface

The *GSE tech-motive tool* CS4000 Mini Controller with Ethernet typically is used with *tech-motive tool* Intelligent nutrunners in a multi-spindle fastening system that communicates with other operations in an assembly process over an Ethernet network. When used in this context, the controller contains an Ethernet interface card and the RJ-45 connector that is used to link it to a host computer (that contains an Ethernet network card). The Ethernet interface card in each device enables communication via the network hub.

The CS4000 Mini Controller with Ethernet can optionally communicate over a 485 network. For this application, it has an RS-485 connector and is linked to a host computer that contains a Synchronous Data Link Control (SDLC) card.

In either scenario, the host computer is loaded with the *tech-motive tool* Visual Supervisor (VS) setup, graphing and diagnostics program. Version 3.20 is used to program the parameters of each *tech-motive* spindle (controller and nutrunner) in the network, remains on the host computer, and is thus said to operate in *permanent* mode.

When operating a nutrunner off-network (in a single spindle, stand-alone system), the controller is programmed using VS from a laptop PC, which is linked via cable to the RS-232 serial port on the controller. Because the laptop can be disconnected from one CS4000 Mini Controller and reconnected to another, VS is said to operate in *portable* mode.

An optional Interbus-S module can be added to the CS4000 Mini Controller with Ethernet, typically to connect the controller to a Programmable Logic Controller (PLC). The module adds eight soft-programmable digital inputs and eight soft-programmable digital outputs to the system.

## Who Should Use This Manual

This manual is written for the engineers, technicians and users who will set-up and/or operate the CS4000 Mini Controller with Ethernet with any of the Intelligent (46, 66 or 116) nutrunners.

## How to Use This Manual

This manual provides installation, maintenance and technical information about the CS4000 Mini Controllers with Ethernet.

This Preface provides conventions and abbreviations used throughout this manual.

If you have never used a CS4000 Mini Controller with Ethernet, read this manual entirely. The first three chapters will help you become familiar with safety requirements, the location of components, software and features.

If you are already familiar with the CS4000 Mini Controller, look over *Chapter 4. Installing the CS4000 Mini Controller with Ethernet*, which describes the power requirements and details the I/O wiring and connectors.

If you want to use the CS4000 Mini Controller with Ethernet with a network or laptop computer, refer to *Chapter 5. Setting Up the Ethernet*, *Chapter 6. Setting Up the 485 Network* and *Chapter 7. Setting Up the RS-232 Link* that describe the methods by which you can connect the CS4000 Mini Controller to a network or laptop computer.

You will find *Chapter 8. Maintenance/Troubleshooting* and *Chapter 9. Technical Information* provide you with technical details for maintaining and troubleshooting the controller.

## Conventions

The following conventions are used throughout this manual for the safety of personnel, equipment, software, and data. The conventions include warnings, cautions and notes, as follows:

***WARNING!*** Information inside the ***WARNING!*** box concerns the protection of either personnel (or an action that could result in a systems failure). The information is indented and in italicized boldface type.

***CAUTION!*** Information next to ***CAUTION!*** concerns the protection of equipment, software, and data. The information is indented and in italicized boldface type.

***NOTE:*** Information next to the ***NOTE*** caption is designed to bring your attention to a certain characteristic of software or hardware operation. The information is indented and italicized.

## Abbreviations

Some of the most common abbreviations used throughout this manual include the following:

<b>API</b>	Application Program Interface
<b>GFCI</b>	Ground Fault Circuit Interrupter
<b>I/O</b>	Input/Output
<b>IEEE</b>	Institute of Electrical and Electronic Engineers
<b>IP</b>	Internet Protocol
<b>kbps</b>	kilo-bits per second
<b>kVA</b>	kilovolt-ampere
<b>LAN</b>	Local Area Network
<b>LED</b>	Light Emitting Diode
<b>mbps</b>	million bits per second
<b>PCI</b>	Peripheral Component Interconnect
<b>TCM</b>	Tool Control Module
<b>TCP/IP</b>	Transmission Control Protocol/Internet Protocol
<b>RAM</b>	Random Access Memory
<b>SDLC</b>	Synchronous Data Link Control
<b>TINI</b>	<u>T</u> INI <u>I</u> nternet <u>I</u> nterface
<b>V</b>	Volts



(This page is left blank intentionally.)



# Contents

<b>Preface .....</b>	<b>iii</b>
<b>Who Should Use This Manual .....</b>	<b>iii</b>
<b>How to Use This Manual .....</b>	<b>iii</b>
<b>Conventions .....</b>	<b>iv</b>
<b>Abbreviations .....</b>	<b>v</b>
<b>1. Overview .....</b>	<b>1-1</b>
<b>Receiving, Sending and Storing Data .....</b>	<b>1-1</b>
<b>Using Ethernet .....</b>	<b>1-2</b>
Example of a “Permanent” (Embedded) Ethernet Network .....	1-3
<b>Using a 485 Network using SDLC .....</b>	<b>1-4</b>
Example of a “Permanent” (Embedded) 485 Network .....	1-5
(Using CS4000 KDM and Mini Controllers with SDLC) .....	1-5
<b>Using the RS-232 Serial Port .....</b>	<b>1-6</b>
<b>Using an Interbus-S Digital I/O Module .....</b>	<b>1-6</b>
<b>Using the Siemens 3964R Barcode Protocol .....</b>	<b>1-7</b>
<b>Deciding How to Set Up the Controller .....</b>	<b>1-7</b>
<b>2. Think Safety First! .....</b>	<b>2-1</b>
General Machine Safety .....	2-2
Electrical Safety .....	2-3
<b>3. Identifying the Components .....</b>	<b>3-1</b>
<b>Front Panel .....</b>	<b>3-2</b>
LED Display .....	3-2
Parameter Set Switch .....	3-3
Access Screws .....	3-3
<b>Top and Bottom Panel .....</b>	<b>3-3</b>
AC Power Cord .....	3-3
Interbus-S I/O Connector .....	3-3
I/O Connector .....	3-4
Tool Connector .....	3-4
RS-422 Connector .....	3-5
Ethernet Connector .....	3-5
Printer/Barcode Connector .....	3-5
SDLC I/O Network Connector .....	3-5
RS-232 Connector .....	3-5
Ground Fault Circuit Interrupter .....	3-5
Fuses .....	3-6

<b>Enclosure Interior</b> .....	3-6
Tool Control Module.....	3-8
Servo Amplifier .....	3-10
Device Control Module .....	3-10
Backplane .....	3-11
Backplane Fuses.....	3-12
Address Switches.....	3-12
I/O Board.....	3-13
Power Supply.....	3-13
Ethernet Interface Card.....	3-14
Interbus-S Module.....	3-16
Ground Fault Circuit Interrupter .....	3-18
Fuses .....	3-18
<b>4. Installing the CS4000 Mini Controller with Ethernet</b> .....	<b>4-1</b>
<b>Mounting the CS4000 Mini Controller with Ethernet</b> .....	4-1
<b>Power and Connection-Requirements</b> .....	4-3
<b>Meeting the AC Input Power Requirements</b> .....	4-4
<b>Grounding</b> .....	4-4
<b>I/O Wiring</b> .....	4-5
<b>Connector Pinout Definitions</b> .....	4-11
Tool Connector .....	4-11
I/O Connector.....	4-11
RS-422 Connector .....	4-12
Tool Control Module (TCM) Network Connector .....	4-12
RS-232 Connector .....	4-12
Printer/Barcode Connector .....	4-12
Interbus-S “IN” Connector.....	4-12
Interbus-S “OUT” Connector.....	4-13
<b>5. Setting Up the Ethernet</b> .....	<b>5-1</b>
<b>Programming the Ethernet Interface Card</b> .....	5-1
Working with the IP Address, Subnet Mask and Default Gateways .....	5-1
Updating Application Settings .....	5-10
<b>Setting Up Visual Supervisor for an Ethernet Network</b> .....	5-13
Editing VSMMain.ini for an Ethernet Network.....	5-14
<b>Using Ethernet Network Cables</b> .....	5-16
Testing the Ethernet Network.....	5-17
Testing Ethernet Network Cables .....	5-24
<b>6. Setting Up the 485 Network</b> .....	<b>6-1</b>
<b>Installing the SDLC Card</b> .....	6-1
<b>Setting Up Visual Supervisor for a 485 Network</b> .....	6-1
Editing VSMMain.ini for a 485 Network .....	6-2
Assigning A Network Address.....	6-4
Using 485 Network Cables .....	6-7

<b>7. Setting Up the RS-232 Link.....</b>	<b>7-1</b>
<b>Setting Up Visual Supervisor .....</b>	<b>7-1</b>
<b>Using RS-232 Cables.....</b>	<b>7-1</b>
<b>8. Maintenance/Troubleshooting .....</b>	<b>8-1</b>
<b>Replacement Parts .....</b>	<b>8-1</b>
<b>Replacing Main Power Fuses .....</b>	<b>8-2</b>
<b>Replacing Backplane Fuses .....</b>	<b>8-2</b>
<b>Cleaning the Enclosure Window.....</b>	<b>8-2</b>
<b>Troubleshooting .....</b>	<b>8-3</b>
Ethernet Network .....	8-3
RS-422 (Siemen's 3964R) Interface .....	8-4
Application Program Interface (API).....	8-4
<b>9. Technical Information .....</b>	<b>9-1</b>
<b>Assembly Drawing.....</b>	<b>9-1</b>
<b>Index.....</b>	<b>Index-1</b>

# Figures

Figure 1-1.	Example of an Ethernet Network with a Connected Portable Laptop.....	1-3
Figure 1-2.	Example of a 485 Network.....	1-5
Figure 3-1.	Front Panel View.....	3-2
Figure 3-2.	Top Panel View.....	3-3
Figure 3-3.	Bottom Panel View.....	3-4
Figure 3-4.	Components Inside the Enclosure of the CS4000 Mini Controller with Ethernet .....	3-7
Figure 3-5.	Front View of the TCM.....	3-8
Figure 3-6.	Rear View of the TCM and Location of the Servo Amplifier Fuse .....	3-9
Figure 3-7.	DCM Board and DCM Battery Location .....	3-10
Figure 3-8.	CS4000 Mini Controller with Ethernet Backplane .....	3-11
Figure 3-9.	I/O Board .....	3-13
Figure 3-10.	Ethernet Interface Card .....	3-14
Figure 3-11.	Interbus-S Module Side View.....	3-16
Figure 3-12.	Interbus-S Module Top View .....	3-17
Figure 3-13.	Ground Fault Circuit Interrupter .....	3-18
Figure 4-1.	CS4000 Mini Controller with Ethernet Dimensions .....	4-2
Figure 4-2.	Power/Connection Requirements .....	4-3
Figure 4-3.	Remote Input Circuit Schematics .....	4-8
Figure 4-4.	Example of CS4000 Controller Remote I/O Wiring – Sourcing Outputs .....	4-9
Figure 4-5.	Example of CS4000 Controller Remote I/O Wiring – Sinking Outputs.....	4-10
Figure 5-1.	Message Upon Starting the TINI Ethernet Interface Flash Utility .....	5-3
Figure 5-2.	Selecting the COM Port Menu .....	5-4
Figure 5-3.	Selecting ‘COM1’ RS-232 Port .....	5-4
Figure 5-4.	Establishing A Successful Connection via COM1 .....	5-5
Figure 5-5.	Error Message Displayed when COM1 is Already In Use .....	5-5
Figure 5-6.	Selecting the “Flash TINI...” Option.....	5-6
Figure 5-7.	Selecting the Application File.....	5-6
Figure 5-8.	Error Message Displayed when the Attempted Connection Fails.....	5-7
Figure 5-9.	Error Message Following An Unsuccessful Flash Attempt.....	5-7
Figure 5-10.	Second Error Message Following An Unsuccessful Flash Attempt.....	5-7
Figure 5-11.	Confirming the IP Address, Subnet Mask and Default Gateway .....	5-8
Figure 5-12.	Selecting the “Set TINI Application Info...” Menu Option.....	5-10
Figure 5-13.	Viewing the Application Settings Window - General Info tab.....	5-11
Figure 5-14.	Selecting the Application Settings Window - Ip Address tab .....	5-11
Figure 5-15.	Selecting the Application Settings Window - Comm Options tab .....	5-12
Figure 5-16.	VSM <code>ain.ini</code> configured for an Ethernet Network.....	5-14
Figure 5-17.	Select the Icon and Enter A Name for the Hyperterminal Connection.....	5-18
Figure 5-18.	Select Communications Port .....	5-19
Figure 5-19.	Setting the Communications Port Settings .....	5-20
Figure 5-20.	Hyperterminal Window Showing Ethernet Interface Card (TINI) Login Prompt .....	5-21
Figure 5-21.	Opening the Command Prompt Window .....	5-23

Figure 6-1.	<i>VSMain.ini</i> configured for a 485 Network.....	6-2
Figure 6-2.	Network Address DIP Switch Set for Address '5'.....	6-5
Figure 9-1.	CS4000 Mini Controller with Ethernet Wiring of Standard Ethernet and Interbus-S Module.....	9-3
Figure 9-2.	CS4000 Mini Controller with Ethernet Wiring of Standard Ethernet .....	9-5

## Tables

Table 3-1.	Description of Ethernet Interface Card LEDs.....	3-15
Table 3-2.	Description of LEDs on the Side of the Interbus-S Module.....	3-17
Table 3-3.	Description of LEDs on the Top of the Interbus-S Module.....	3-17
Table 4-1.	19-Position Remote I/O Connector Pinout Signal Names and Descriptions ..	4-5
Table 4-2.	Guidelines for Proper Operation of the Controller I/O Signals .....	4-8
Table 5-1.	Ethernet RJ-45 Modular Jack Pinout .....	5-16
Table 6-1.	Switch Positions Representing Binary Numbers.....	6-4
Table 6-2.	Setting Address Switches .....	6-4
Table 8-1.	Replacement Parts .....	8-1
Table 8-2.	Ethernet Common Problems and Solutions.....	8-3

## Procedures

Procedure 5-1.	Programming the Ethernet Interface Card.....	5-2
Procedure 5-2.	Editing Application Information.....	5-10
Procedure 5-3.	Editing <i>VSMain.ini</i> for an Ethernet Network .....	5-15
Procedure 5-4.	Testing the Network From A Laptop Computer .....	5-17
Procedure 5-5.	Testing the Network From A Host Computer.....	5-23
Procedure 6-1.	Editing <i>VSMain.ini</i> for a 485 Network.....	6-3
Procedure 6-2.	Setting the Address for the Controller .....	6-6

(This page is left blank intentionally.)

# 1. Overview

The *GSE tech-motive tool* CS4000 Mini Controller with Ethernet is the control component of one of the most powerful DC electric nutrunner fastening control systems available. The system uses 100% digital technology to ensure accurate and reliable fastening, and torque angle data acquisition. Microprocessors in both the tool (nutrunner) and the controller enable the system to perform to levels of accuracy while providing easy setup and operation.

The system uses the industry's first truly "Intelligent Tools." With this technology you no longer need to key tool identification, calibration, angle counts, speed and other information into the controller. You simply plug in the tool, power up the system, program the desired tightening parameters and begin production.

A complete fastening system is made up of the CS4000 Mini Controller (with or without) Ethernet, a *tech-motive tool* nutrunner (46, 66 or 116 Series) and a standard *tech-motive tool* cable. The CS4000 Mini Controller with Ethernet houses one Tool Control Module (TCM), with fuses and ground fault circuit interrupt (GFCI) protection. The powerful *tech-motive tool* Visual Supervisor software program is used for system setup, graphing and diagnostics.

Visual Supervisor runs on a computer attached to the controller, using:

- An Ethernet link, using an Ethernet interface card and an Ethernet RJ-45 port.
- A 485 network link, using a Synchronous Data Link Control (SDLC) card and RS-485 port.
- An RS-232 compatible serial port.

*NOTE: To find out more about using the Visual Supervisor software, refer to the Visual Supervisor User's Guide (part number 39-30-34823).*

## Receiving, Sending and Storing Data

You can use the following methods to link one or more controllers to the Visual Supervisor program and/or I/O communications devices:

- An Ethernet link to a local area network (LAN). Here the controller has the standard Transmission Control Protocol/Internet Protocol (TCP/IP), an Ethernet interface card, and an Ethernet RJ-45 port.
- A 485 network link to a LAN. Here the computer uses an SDLC card inserted into a free Peripheral Component Interconnect (PCI) slot, and an RS-485 port on the controller.

***CAUTION! The 485 network and Ethernet link perform the same function. If you set up the controller to use the 485 network, you will not need the Ethernet link, nor vice versa.***

- An RS-232 serial link to a laptop computer using the RS-232 serial port.



- A digital I/O communications link, using the optional Interbus-S digital I/O module in the controller. The Interbus-S module does not connect the controller to a network, but does allow I/O communications between the controller and a Programmable Logic Controller (PLC), or other similar device.

To help you decide which method you require, read the rest of this chapter.

If you choose the Ethernet or 485 network method, the Visual Supervisor software installed on the computer attached to the network allows you to make changes to controllers across the network and monitor them. This supervisory computer is commonly referred to throughout this manual as the **host**. It is also possible to connect a laptop, via a cable and the RS-232 compatible serial port, to any controller on the network and make individual changes to that controller. Refer to *Using the RS-232 Serial Port* later in this chapter for details.

*NOTE: To program controllers across the network, and successfully use an attached laptop to view, edit or collect data from a controller on the network, you must have Visual Supervisor version 3.20 or higher installed on the host and laptop computers, and DCM 4.06 or higher installed on the controllers.*

The CS4000 Mini Controller with Ethernet also has an optional Application Program Interface (API) which you can have built into each controller. This allows you to collect rundown data and send it to a software application across the Ethernet network, other than Visual Supervisor.

*NOTE: The API can be run concurrently with Visual Supervisor allowing you to collect rundown data in Visual Supervisor and also send it to another application, via the API.*

## Using Ethernet

The Ethernet is a Local Area Network (LAN) technology developed by Xerox and then further developed by Xerox, Digital Equipment Corporation (DEC), and Intel. The CS4000 Mini Controller with Ethernet uses the most commonly installed type of Ethernet cable, 10Base-T. This type of cable can provide transmission speeds of up to 10 million bits per second (Mbps) and uses the standard Transmission Control Protocol/Internet Protocol (TCP/IP) communications protocol.

This is a *permanent* mode of operation in which the computer and controllers are connected via the same network hub. See Figure 1-1.

This type of network requires:

- Pentium Class computer (500 MHz or above).
- Microsoft Windows 95, 98, 2000, or Windows NT, version 4.0 or above with TCP/IP communications protocol installed.
- At least 64 MB RAM for Windows 95, 98 or 2000, or 128 MB RAM for Windows NT.
- Installed Ethernet Interface Card in the controller and the computer.
- Visual Supervisor installed in *permanent* mode.
- Shielded 10Base-T cable and Ethernet connector.

In this configuration, the host computer running Visual Supervisor provides data collection, diagnostics and configuration functions for all the controllers, but the hub is the connection point for the LAN. See Figure 1-1 for details. To set up an Ethernet network, refer to *Chapter 5. Setting Up the Ethernet*.

## Example of a “Permanent” (Embedded) Ethernet Network (Using Mini Controllers with Ethernet)

Pentium Class Computer running Windows 95, 98, 2000 or Windows NT, version 4.0 or above. It also has an installed Ethernet interface card. Each controller has an Ethernet connector.

Visual Supervisor is running on the computer, plus an optional Application Program Interface (API) for data collection.

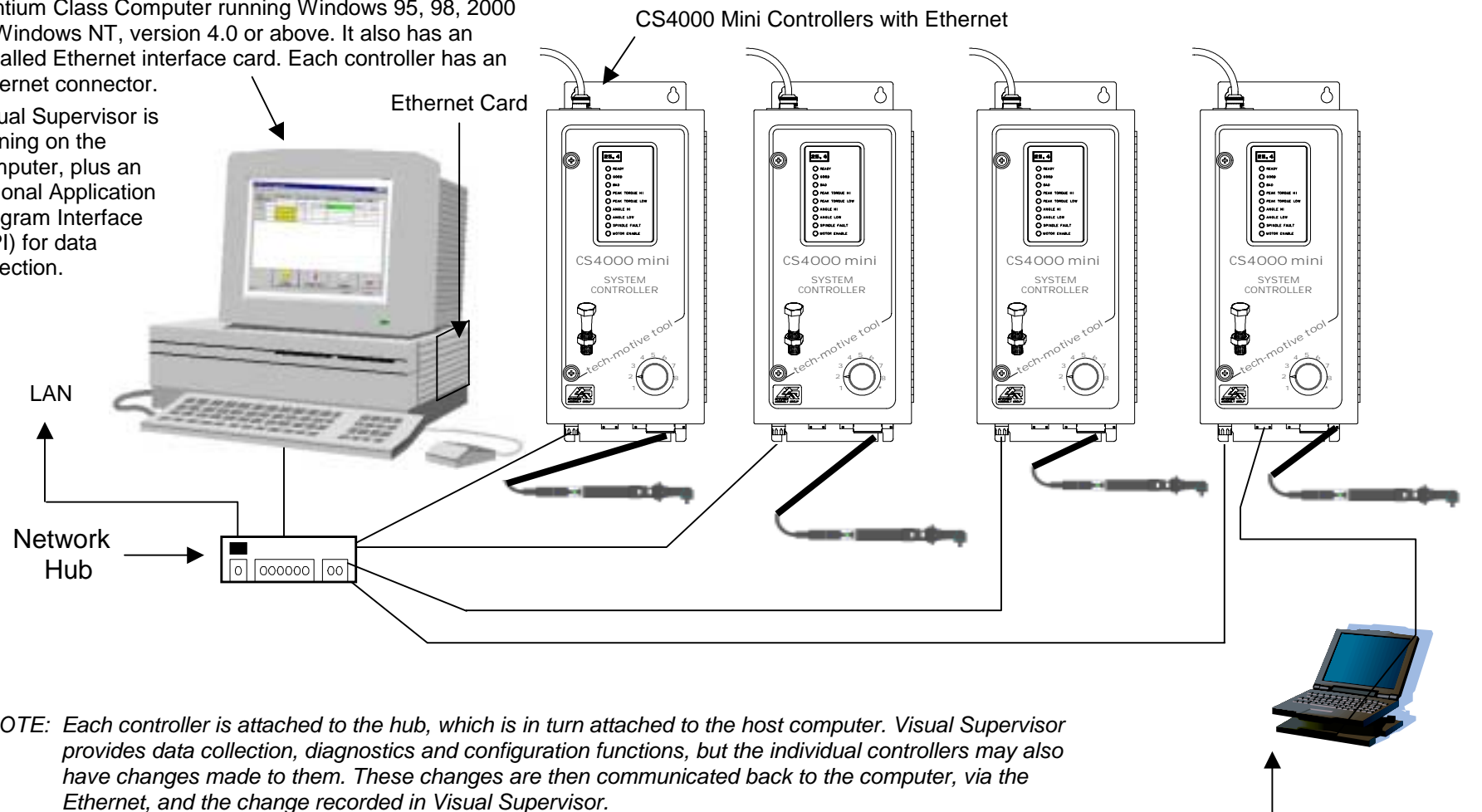

*NOTE: Each controller is attached to the hub, which is in turn attached to the host computer. Visual Supervisor provides data collection, diagnostics and configuration functions, but the individual controllers may also have changes made to them. These changes are then communicated back to the computer, via the Ethernet, and the change recorded in Visual Supervisor.*

**Figure 1-1. Example of an Ethernet Network with a Connected Portable Laptop**

A laptop running Visual Supervisor is attached, via an RS-232 compatible port, and used to make setup changes for an individual controller on or off the network.

## Using a 485 Network using SDLC

In a 485 network, the controller is linked to a LAN, via cable between the first controller's RS-485 connector and the port for the Synchronous Data Link Control (SDLC) card installed on the host computer. Each controller in the 485 network is connected to the next in a *daisy chain* fashion. The computer is connected to the first controller, the first controller is connected to the second controller, and so on until the network terminates with the last controller. See Figure 1-2. In this mode of operation, you can have as many as 32 TCMs attached and running from a single supervising computer.

This type of network requires:

- Pentium class computer (500 MHz or above).
- Microsoft Windows NT, version 4.0 or above.
- At least 128 MB RAM.
- Installed SDLC card.
- Visual Supervisor installed on the computer in *permanent* mode.
- RS-485 cable and connector.

In this configuration, the computer permanently connected to the network runs Visual Supervisor which now takes on the role of supervising all of the controllers on the LAN for both data and parameter set information, as well as being the connection point for the LAN. To set up a 485 network, refer to *Chapter 6. Setting Up the 485 Network*.

## Example of a “Permanent” (Embedded) 485 Network (Using CS4000 KDM and Mini Controllers with SDLC)

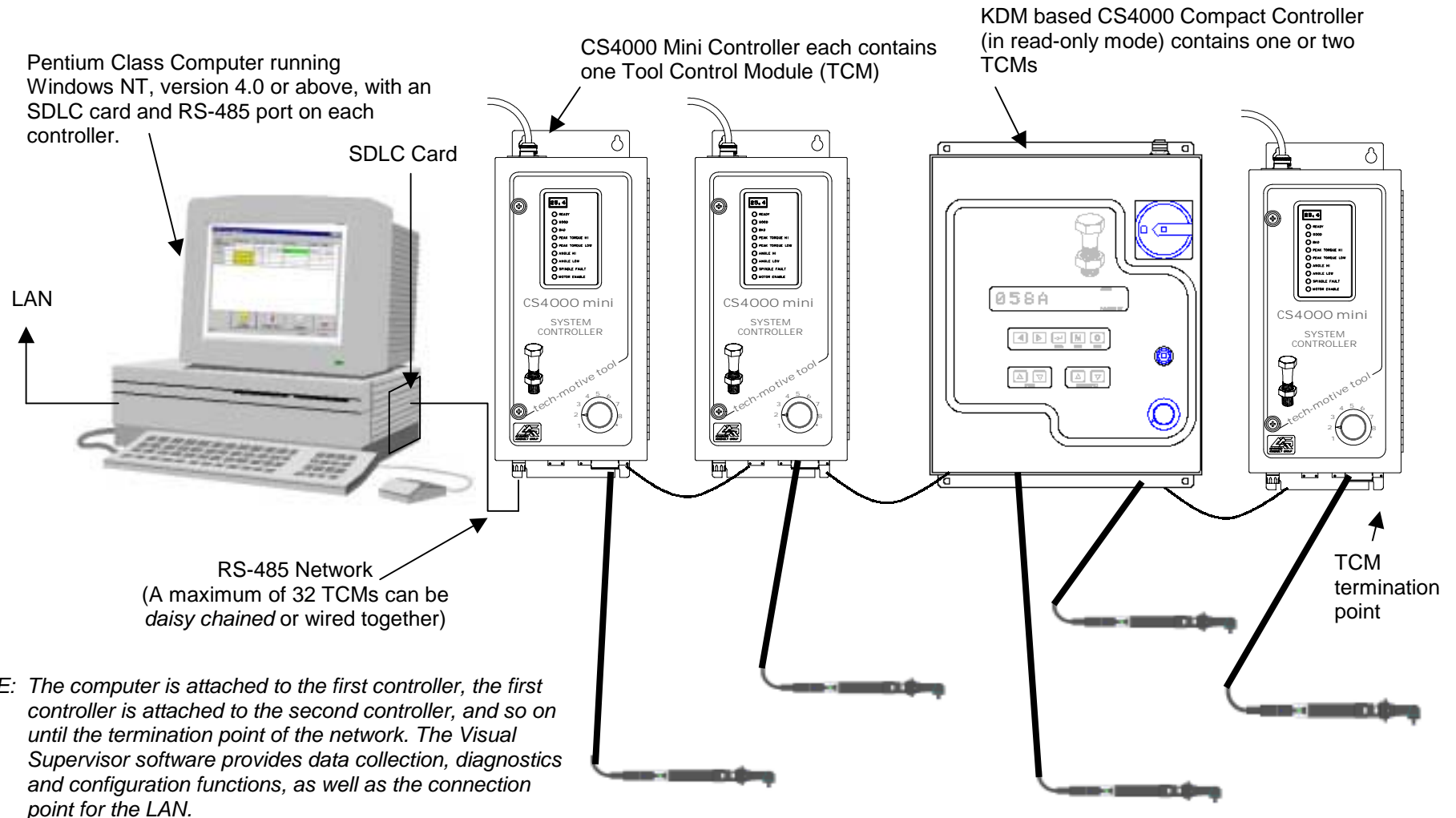

Figure 1-2. Example of a 485 Network

## Using the RS-232 Serial Port

In this configuration, a laptop PC loaded with the Visual Supervisor software is linked to the controller's RS-232 serial port. See Figure 1-1 on page 1-3. Because the laptop can be disconnected from one Mini Controller and reconnected to another, VS is said to be operating in *portable* mode. The controller in this scenario may not be part of a network typically so that it, the cable and nutrunner comprise a stand-alone fastening system.

This type of operation requires:

- Pentium class laptop computer.
- Microsoft Windows 95, 98, 2000, or Windows NT version 3.0 or above.
- At least 64 MB RAM for Windows 95, 98 or 2000, or 128 MB RAM for Windows NT.
- Visual Supervisor installed on the laptop in *portable* mode.
- RS-232 cable and connector.

If the laptop PC is connected to a controller that is also connected to a network, the host computer adopts any changes made by the laptop PC to the controller. While the laptop computer is making changes, the host cannot make setup changes to the same controller. The Visual Supervisor program being run by the host computer grays out every field for that particular controller. When the laptop PC is no longer connected to the controller, the host computer can once again make changes.

*NOTE: To attach and use a laptop to view, edit or collect data from a controller on a network, you must have Visual Supervisor version 3.20 or higher installed on the host and laptop computers, and DCM 4.06 or higher installed on the controllers.*

## Using an Interbus-S Digital I/O Module

The optional Interbus-S module can be added to the controller, to provide eight soft-programmable digital inputs and eight soft-programmable digital outputs. You can assign the function of these inputs and outputs using the Visual Supervisor program. Refer to the Visual Supervisor User's Guide (part number 39-40-34823) for details.

You can use the Interbus-S module to connect the controller to a Programmable Logic Controller (PLC). When the PLC reads a barcode successfully, for example, it sends a signal as an Interbus-S module input into the controller that tells the controller to allow the operator to perform a rundown. The controller then sends a signal to the PLC as an Interbus-S module output that indicates when a good rundown or a bad rundown has been performed.

## Using the Siemens 3964R Barcode Protocol

The RS-422 port on the controller supports the Siemens 3964R barcode protocol. This protocol provides an error checked point-to-point method of sending barcode data to the controller. If the controller receives a corrupt or incomplete barcode, the scanner sends the barcode information again.

For example, you might choose to attach a barcode scanner and controllers to the same RS-422 network. A barcode is read by the scanner, which then sends the barcode to every controller attached to the network. This means you do not have to scan the barcode at each individual controller.

*NOTE: If, for any reason, the scanner does not send a barcode using the RS-422 port, then the Printer/Barcode port on each controller provides you with a backup. You can always scan the barcode at an individual controller using a scanner attached to the Printer/Barcode serial port until the scanner attached to the RS-422 port starts sending barcode data again.*

For further details about the Siemens 3964R Barcode Protocol, refer to the Protocol Definition of the 3964/3964R Procedures available from Siemens (Siemens Part Number C79000-B8576-C191-01).

## Deciding How to Set Up the Controller

It is more than likely that you will not need to use all methods of connecting the controller to a network and/or external devices. If you decide to use the 485 network link then you will not need the Ethernet link, nor vice versa, as they perform the same function. You may or may not want the controller to communicate with a PLC and/or an external barcode scanner, in which case, you do not need an Interbus-S I/O module or a link via the RS-422 port.

The following chapter describes the basic components of the controller so you can familiarize yourself with them before you install it. *Chapter 4. Installing the CS4000 Mini Controller with Ethernet* describes how to mount the controller and how to make sure you fulfill its power requirements. *Chapter 5. Setting Up the Ethernet*, *Chapter 6. Setting Up the 485 Network* and *Chapter 7. Setting Up the RS-232 Link* describe how to install the various components that have been discussed in this chapter.

(This page is left blank intentionally.)

## 2. Think Safety First!

Working with fastening tools can be dangerous if safe and proper procedures are not followed. As with all machinery, certain hazards can be involved with the operation of the product. Using these tools with respect and caution will considerably lessen the possibility of personal injury, however, if normal safety precautions are overlooked or ignored personal injury to the operator may result.

Always use common sense and exercise caution when using these tools. They can produce high torque that, unless properly compensated for, could cause personal injury. Remember, your personal safety is *your* responsibility.

Only *GSE tech-motive tool*-qualified service technicians should perform the procedures covered in this manual. If you are an operator or service technician, you should become familiar with the contents of this manual before operating, servicing, or maintaining any part of the CS4000 Mini Controller with Ethernet, including the 66 Series fastening tools. Familiarization with all components of the system can minimize the possibility that an accident or injury might occur.

*GSE tech-motive tool* assumes no responsibility for personal injury or damage to equipment resulting from misuse of these tools. After reviewing this manual you should also review all safety procedures provided by your company and the equipment installer.

***WARNING! Failure to follow these steps may result in serious personal injury.***



## General Machine Safety

- FOR YOUR OWN SAFETY READ THE INSTRUCTION MANUAL THOROUGHLY PRIOR TO OPERATING THE TOOL.
- DO NOT WORK IN A DANGEROUS ENVIRONMENT. Do not use power tools in a damp or wet location or expose them to rain, oils, or corrosive fluids.
- KNOW THE LOCATION OF POWER DISCONNECTS AND EMERGENCY STOP BUTTONS PRIOR TO OPERATING THIS EQUIPMENT.
- KEEP ALL ELECTRICAL PANELS CLOSED DURING OPERATION. High voltage present inside enclosure panels can result in personal injury. Do NOT bypass or defeat electrical safety devices. Turn the power actuator to the OFF position prior to any servicing or maintenance of the controller.
- OBSERVE ALL GOVERNMENT AND/OR COMPANY POWER LOCKOUT STANDARDS.
- NEVER OPERATE SOLENOID VALVES, LIMIT SWITCHES OR RELAYS MANUALLY as this practice can create dangerous, unexpected machine movements.
- SECURE THE TOOL. Tools that develop torque can produce hazardous torque reactions. Always be sure that the tool is properly fixtured to absorb reaction as a fastener is tightened. Never operate a tool capable of high torque without proper fixturing.
- SECURE WORK. Avoid situations where the part being fastened breaks loose and can cause damage.
- NEVER TOUCH OR ATTEMPT TO STOP MOVING MACHINERY OR PARTS WITH YOUR HANDS, OTHER PARTS OF YOUR BODY, OR MAKESHIFT DEVICES.
- DO NOT OPERATE THE TOOL WHILE UNDER THE INFLUENCE OF ALCOHOL, DRUGS OR MEDICATION THAT CAN IMPAIR YOUR JUDGMENT.
- REPORT ALL UNSAFE WORKING CONDITIONS OR PRACTICES TO YOUR SUPERVISOR AND / OR SAFETY DEPARTMENT FOR CORRECTION.
- WEAR APPROVED SAFETY GLASSES AT ALL TIMES.
- DO NOT WEAR JEWELRY, especially bracelets and rings, while operating the fastening tools. Keep hands and fingers away from all rotating parts and avoid situations where clothing can become tangled in the tool. Secure loose fitting clothing, neckties, and long hair. Wear medical alert identification cautiously.
- DO NOT OVERREACH. Keep proper footing and balance at all times.
- KEEP YOUR WORK AREA CLEAN. Do not work on or near slippery floors or surfaces. Avoid situations where the tool reacts against unexpected obstacles. Do not operate electrical equipment while standing on a wet floor.

- **MAINTAIN TOOLS IN TOP CONDITION.** Keep tools properly lubricated and clean. If any wires become frayed or exposed, replace them immediately. Prevent dirt, grease or contaminants from getting into the tool.
- **REDUCE THE RISK OF UNINTENTIONAL STARTING.** Be careful how the tool is left unattended. Avoid resting it on its throttle lever to prevent false starts.
- **CONTROL THE DIRECTION OF ROTATION.** The reaction torque changes direction when going from forward to reverse. Always be aware in which direction the tool will rotate prior to using it. If the tool is not fixtured this will allow you to brace for the proper direction of torque reaction.
- **CHECK DAMAGED PARTS.** Before further use of a tool, any part of the tool that is damaged should be carefully checked to ensure that it will operate properly and perform its intended function. Check for alignment of moving parts, breakage of parts, mounting, and any other conditions that may affect its operation. Never operate a tool that has damaged or exposed wires. Never operate a tool that has any part of the powertrain, other than the output spindle, exposed.

## **Electrical Safety**

Only qualified and properly trained personnel should perform electrical/electronic troubleshooting and repair. Consider the following electrical system safety guidelines:

- Before you troubleshoot or service a fastening system station, be sure you have an up-to-date and appropriate set of electrical drawings for that station.
- Remove metal items, such as rings, metal necklaces, wristwatches and jewelry, as these can create electrical hazards. Wear medical alert identification cautiously.
- Wear safety glasses, but avoid wearing those that have metal rims or metal side shields.
- It may be necessary to troubleshoot equipment while the power is ON. ONLY qualified, trained personnel should do this. During these instances, open only the panels, doors, or covers which need to be opened. Know the voltage present at all points before you begin troubleshooting.
- Use properly insulated tools when working on electrical equipment to reduce the possibility of shock. Make sure the insulation is adequate to safeguard against the high voltages present.
- If you must work on the electrical system, be sure the main disconnect switch on the power panel is in the OFF position and locked out with locks from each trade involved in the repair.
- Do not attempt to modify or repair the machine without the approval of the proper authorities.
- Use approved fuse pullers when changing fuses.
- Never use jumper wires or fuse substitutes to replace specified fuses.

- Always use fuses of a capacity smaller than or equal to the safe capacity of the line or the equipment it serves.
- Before you work on any circuit, check it with an appropriate testing device to be sure voltage is not present.
- Install temporary wiring as safely as possible and replace it with permanent wiring as soon as possible. Install grounding wherever it is needed in the final installation. If modifications are made to the system wiring, drawings must be revised to illustrate this change.
- Know how to deal with electrical fires properly. Keep carbon dioxide and powder extinguishers handy.

# 3. Identifying the Components

The CS4000 Mini Controller with Ethernet houses all the standard functions of the standard CS4000 Mini Controller, but also has the ability to communicate across an Ethernet Local Area Network (LAN) using the standard Ethernet protocol, Transmission Control Protocol/Internet Protocol (TCP/IP).

This chapter is designed to familiarize you with the components of the CS4000 Mini Controller with Ethernet. It has three sections to help you locate all the major components easily:

- Front Panel
- Top and Bottom Panel
- Enclosure Interior

Each section includes figures that call out the components. Descriptions of the components follow the figures.

## Front Panel

Figure 3-1 shows the front panel components of the CS4000 Mini Controller with Ethernet.

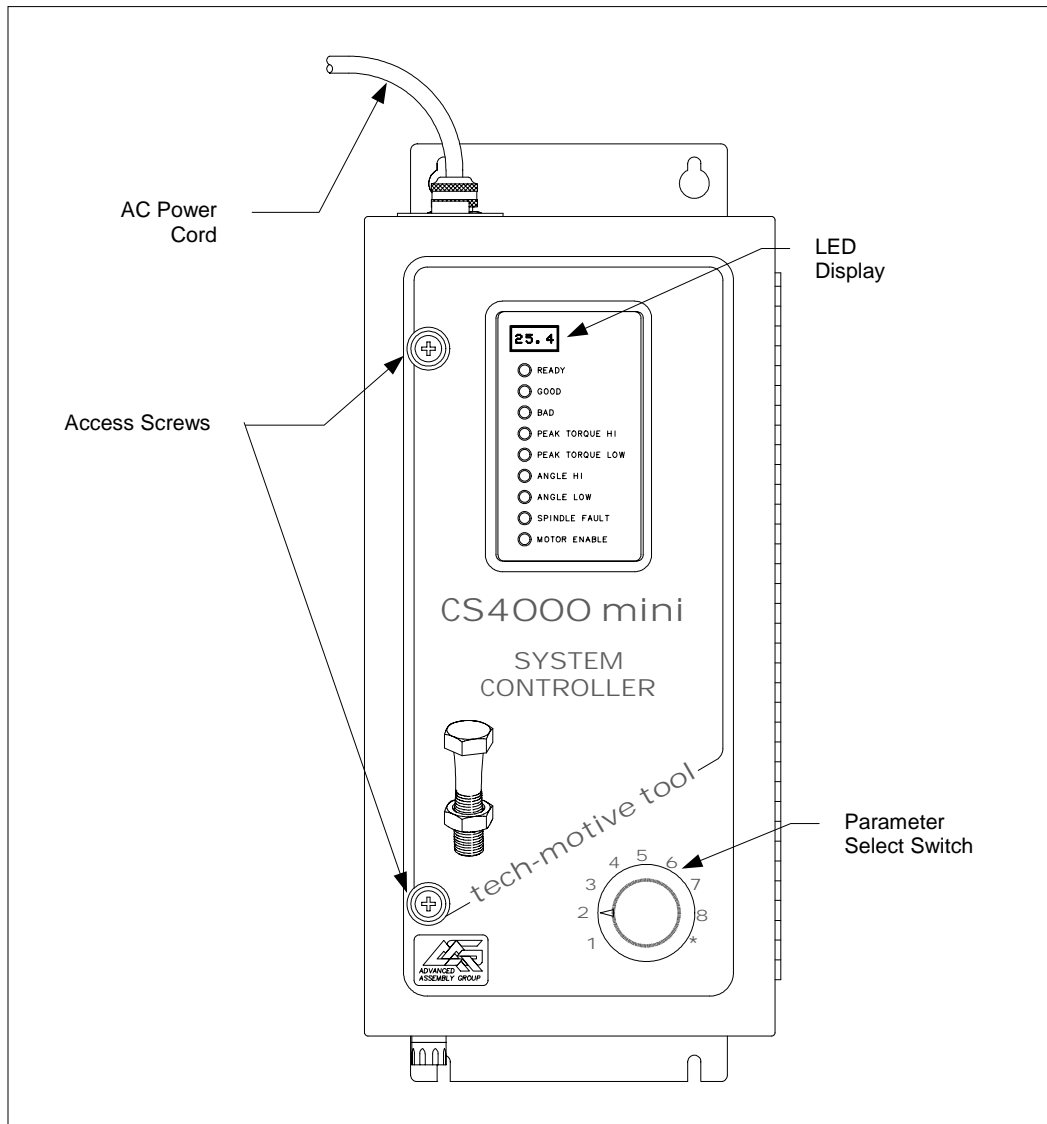

**Figure 3-1. Front Panel View**

*NOTE: The AC power cord is described in the Top and Bottom Panel section later in this chapter.*

### **LED Display**

The LED display shows you the torque, or torque and angle value for the most recent rundown. It also scrolls messages for the operator. For example, if a barcode scan is required before the next rundown, the operator sees a barcode prompt on the LED display.

### Parameter Set Switch

Turn the dial to select the parameter set you wish to use for the next rundown. Select parameter sets using the parameter set switch or Visual Supervisor.

### Access Screws

The access screws keep the front panel of the controller fastened. To un-fasten them you need a No.2 cross-tip (Phillips) head screwdriver.

## Top and Bottom Panel

Figure 3-2 shows the top panel components of the CS4000 Mini Controller with Ethernet.

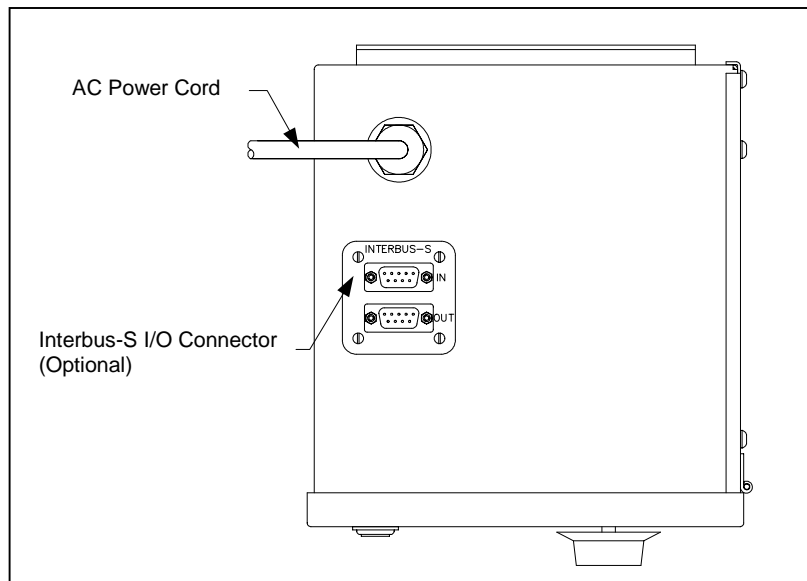

Figure 3-2. Top Panel View

### AC Power Cord

A power cord connection is available on the top of CS4000 Mini Controller with Ethernet. The power cords it accepts are the 6-ft American style 20A, 240V AC power cord (part number 299250-32835) or the 2.5-m European style 10A, 240V power cord (part number 22-30-1021).

### Interbus-S I/O Connector

A nine-position, serial Interbus-S connector may be mounted optionally on the top of the CS4000 Mini Controller with Ethernet. This enables the controller to exchange up to eight digital inputs and outputs with an external Programmable Logic Controller (PLC). If an Interbus-S module is not included in the controller, the Interbus-S I/O connector is covered. To find out details about the Interbus-S module, refer to the *Interbus-S Module* section later in this chapter.

Figure 3-3 shows the bottom panel components of the CS4000 Mini Controller with Ethernet. Descriptions are provided in clockwise order, starting with the I/O connector.

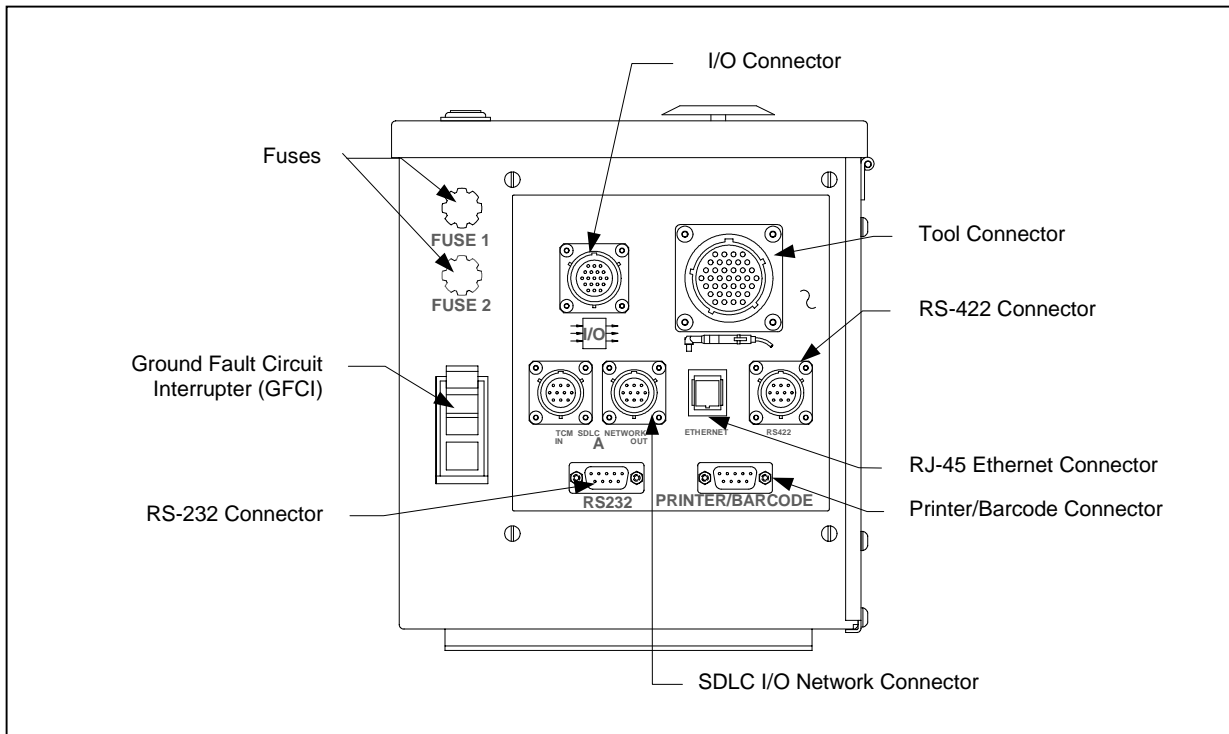

Figure 3-3. Bottom Panel View

### ***I/O Connector***

The 19-position remote I/O connector provides the interface between external control/monitoring devices and the internal control electronics. *tech-motive tool* accessories, such as sockettrays, are connected here.

The mating connector for this port is a 14-shell, 19-pin, strain relief (SR) connector (part number 23-10-5200). The mating connector enables connection of your own remote control and/or monitoring devices, such as external annunciator lamps or remote cycle-on contacts. Refer to *I/O Wiring* in *Chapter 4. Installing the CS4000 Mini Controller with Ethernet* for pinout details.

### ***Tool Connector***

The 37-position connector is the interface between the 46, 66 and 116 Series nutrunner cable and control electronics. Refer to *Connector Pinout Definitions* in *Chapter 4. Installing the CS4000 Mini Controller with Ethernet* for pinout details.

Tool cables are available in lengths of:

- 3 ft / 0.91 m (part number 51-3066-0003)
- 6 ft / 1.83 m (part number 51-3066-0006)
- 10 ft / 3.05 m (part number 51-3066-0010)
- 15 ft / 4.57 m (part number 51-3066-0015)
- 30 ft / 9.14 m (part number 51-3066-0030)
- 50 ft / 15.24 m (part number 51-3066-0050)
- 70 ft / 21.34 m (part number 51-3066-0070)

### ***RS-422 Connector***

The 10-position male asynchronous RS-422 serial I/O connector enables the controller to receive a barcode read by a scanner. The RS-422 communications currently supports the Siemens 3964R barcode protocol.

### ***Ethernet Connector***

The RJ-45 Ethernet connector enables the controller to communicate and send data to and from a host device on the same Local Area Network (LAN) using standard Ethernet protocols (Transmission Control Protocol/Internet Protocol, TCP/IP). Refer to *Chapter 4. Installing the CS4000 Mini Controller with Ethernet* for details.

### ***Printer/Barcode Connector***

The nine-position asynchronous RS-232-compatible serial output connector allows you to use a printer. The printer can be used to generate hard copies of torque, or torque and angle readings, system configuration information, or statistical data upon command from the controller. This port can also be used to receive barcode information.

### ***SDLC I/O Network Connector***

The 10-position female RS-485 connector enables a permanent network connection to and from the controller, other controllers in the network and a permanently connected computer.

### ***RS-232 Connector***

The nine-position asynchronous RS-232 compatible serial output connector allows you to use a laptop computer. The laptop computer can be running the Visual Supervisor software program, the Ethernet Interface Flash Utility, or other program that allows you to program (also referred to as 'flash') the latest Device Control Module and Tool Control Module firmware into the controller.

### ***Ground Fault Circuit Interrupter***

The 250V Ground Fault Circuit Interrupter (GFCI) (part number 13-20-2000) is a safety device, approved by Underwriters Laboratories, that is designed to protect you from potentially dangerous electrical shock.



## **Fuses**

Fuse 1 and Fuse 2 are 15A, 250V, SLO-BLO fuses, Littelfuse 326015 or equivalent (part number 13-10-1015).

## **Enclosure Interior**

The enclosure interior for the CS4000 Mini Controller with Ethernet includes the following components and sub-components:

- Tool Control Module (TCM), that includes:
  - Servo amplifier
  - Servo amplifier fuse (inside TCM)
  - Device Control Module (DCM)
  - DCM battery
  - Backplane
    - Address switch
    - TCM fuse
    - DCM fuse
- TCM I/O power supply (24 VDC)
- Ethernet interface card
- Interbus-S digital I/O module (optional)
- Ground Fault Circuit Interrupter (GFCI)
- Fuses

See Figures Figure 3-4 and Figure 3-3.

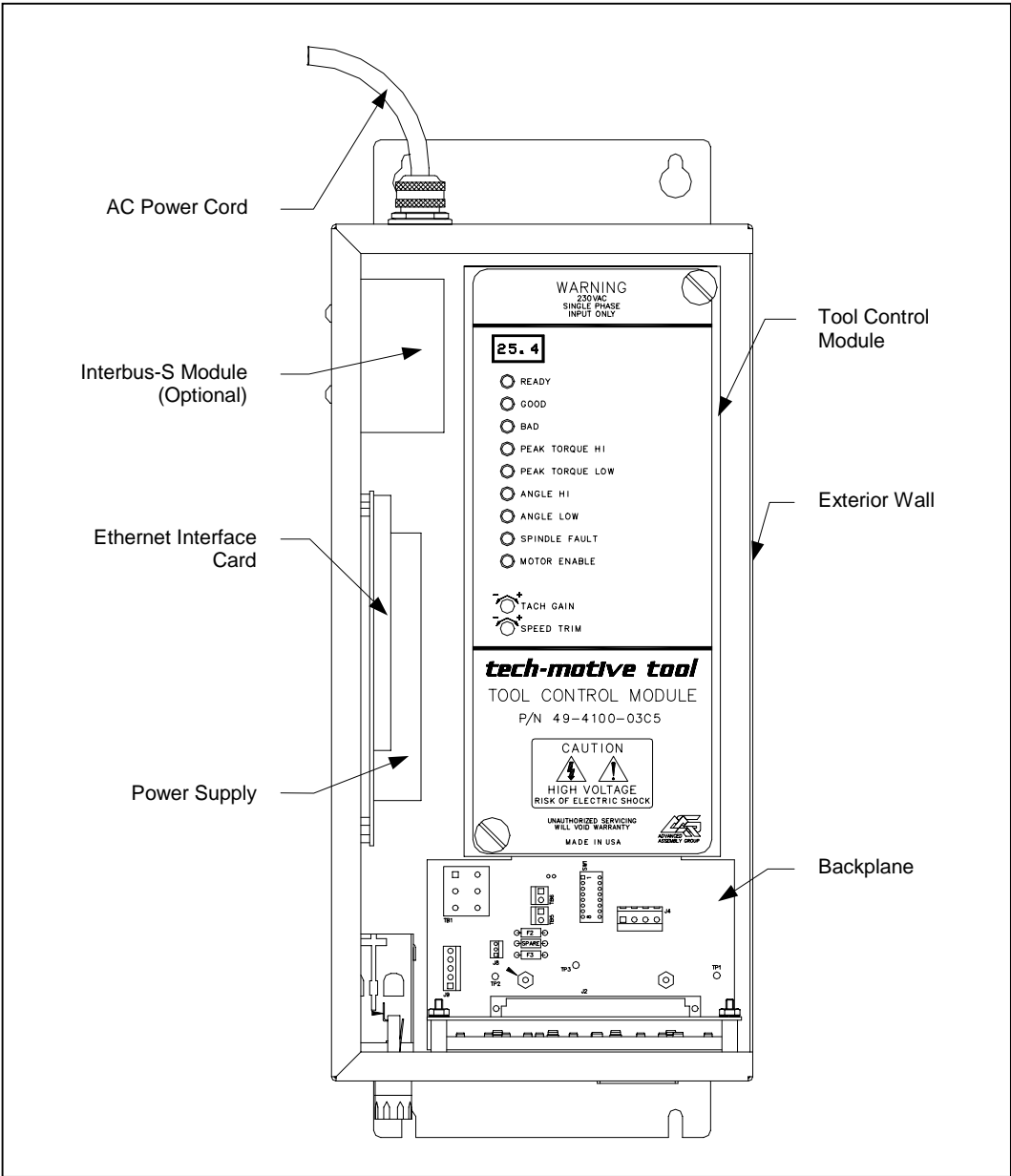

Figure 3-4. Components Inside the Enclosure of the CS4000 Mini Controller with Ethernet

NOTE: The AC power cord is described in Top and Bottom Panel earlier in this chapter.

## Tool Control Module

The Tool Control Module (TCM), shown in Figure 3-5, is a device that controls a single DC electric tool. The TCM and its attached tool are referred to as a spindle. The TCM houses both the servo amplifier and Device Control Module (DCM). For the location of the TCM inside the CS4000 Mini Controller with Ethernet, see Figure 3-4 on page 3-7.

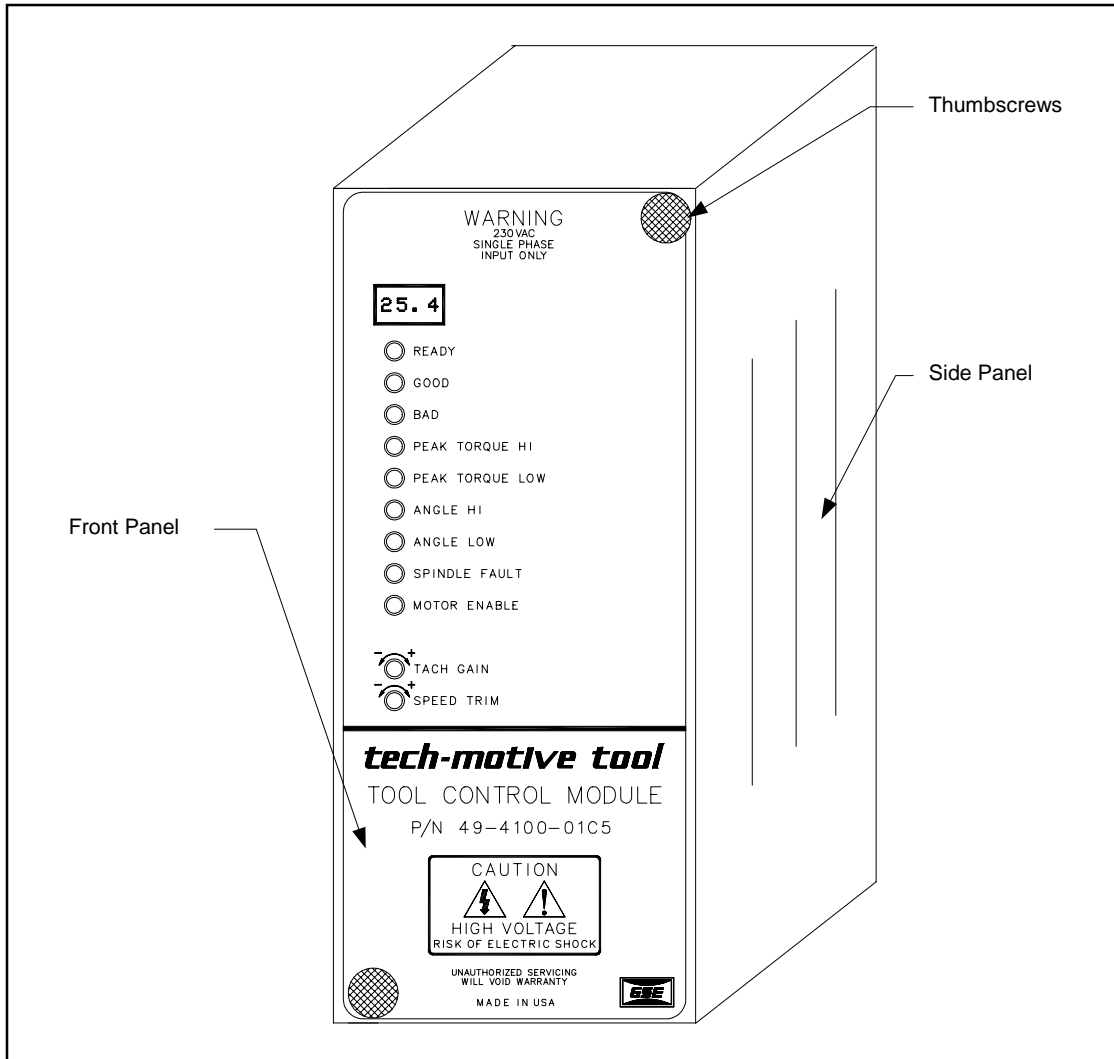

Figure 3-5. Front View of the TCM

The TCM has a small four-digit display, a column of nine indicator LEDs, and two potentiometers. The LEDs provide status and condition information about the connected nutrunner. The indicator LEDs are labeled:

- READY
- GOOD
- BAD
- PEAK TORQUE HI
- PEAK TORQUE LOW
- ANGLE HI
- ANGLE LOW
- SPINDLE FAULT
- MOTOR ENABLE

The potentiometers are labeled:

- TACH GAIN
- SPEED TRIM

When the TCM is removed from the controller, the two servo amplifier boards, servo amplifier fuse, DCM board, and full backplane containing the address switch and TCM fuse can be seen.

Figure 3-6 is a rear view of the TCM. It allows you to see where the two servo amplifier boards, servo amplifier fuse, and DCM are located. Descriptions of the TCM sub-components follow the figure.

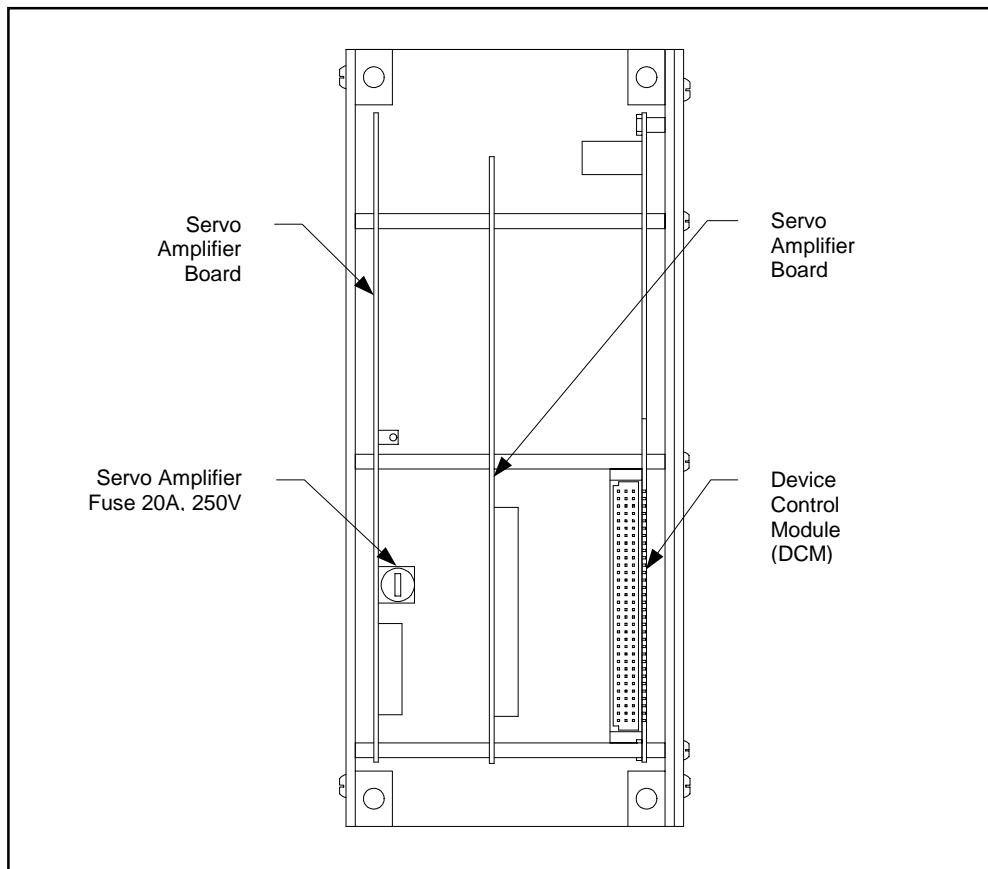

Figure 3-6. Rear View of the TCM and Location of the Servo Amplifier Fuse

### Servo Amplifier

The servo amplifier is a three-phase, brushless DC motor controller that provides electrical power to the nutrunner motor. It receives control signals from the Device Control Module (DCM). Based on the state of these inputs, the servo amplifier energizes the motor windings to rotate the motor.

The servo amplifier serves as a closed-loop speed controller. It modulates the motor winding currents in order to maintain a constant motor speed despite changes in load. Additionally, the servo amplifier can stop the motor quickly by way of dynamic braking. The servo amplifier boards are paired with the DCM board and are housed inside the TCM.

A 20A, 250V servo amplifier fuse (part number 13-10-0700) is located on the first servo amplifier board.

### Device Control Module

The Device Control Module (DCM) is an electronic circuit board that contains powerful 80186EA processor. It is paired with the servo amplifier inside the TCM. The DCM is the brain of the CS4000 Controller with Ethernet. It receives signals from the nutrunner control switches, the set point inputs, the nutrunner torque sensor, and remote control inputs and generates the appropriate outputs to the servo amplifier control inputs, the status output relays, and the nutrunner status LEDs. The DCM has plug-in electrical connections. It is easy to remove and replace.

A 3V lithium battery is located on the DCM board. You must remove the DCM board from the TCM in order to replace this battery. A generic 3V lithium battery (Duracell DL 2450, Sanyo CR 2450, or similar) can be used.

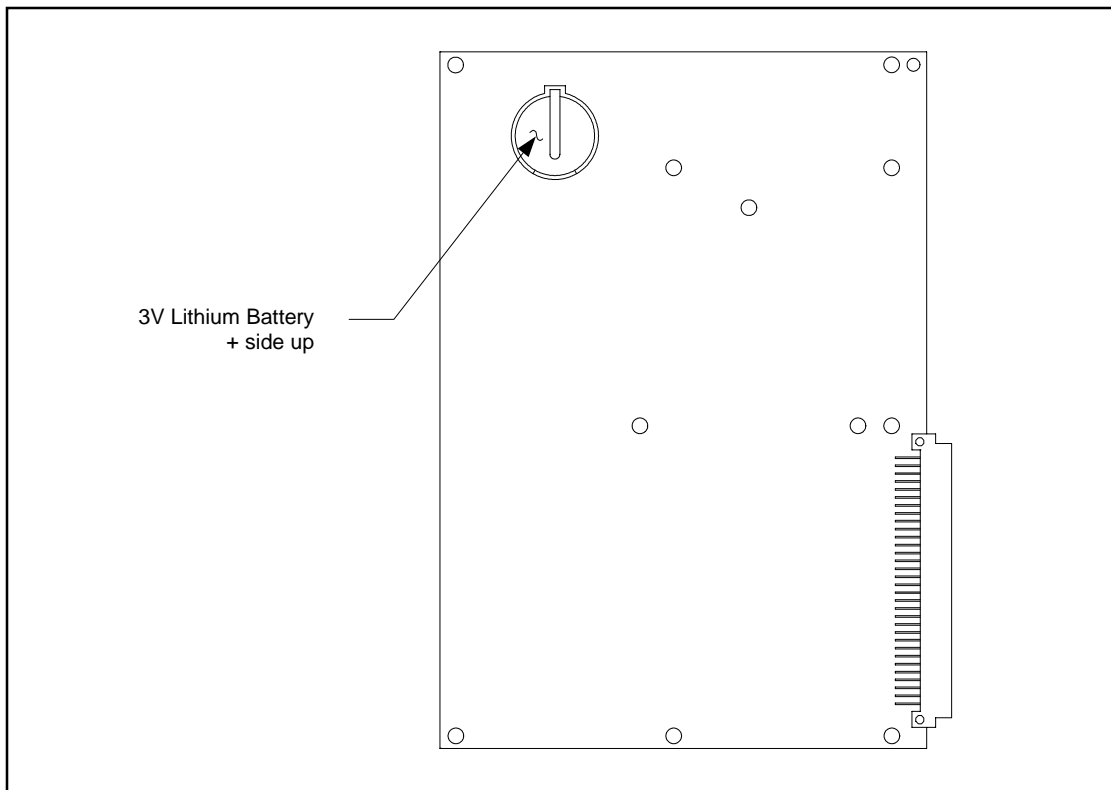

Figure 3-7. DCM Board and DCM Battery Location

### Backplane

The backplane (part number 420890-35327) is a printed circuit board into which many of the internal component cables plug. It also contains address switch SW-1, and the DCM fuse, F4. See Figure 3-8.

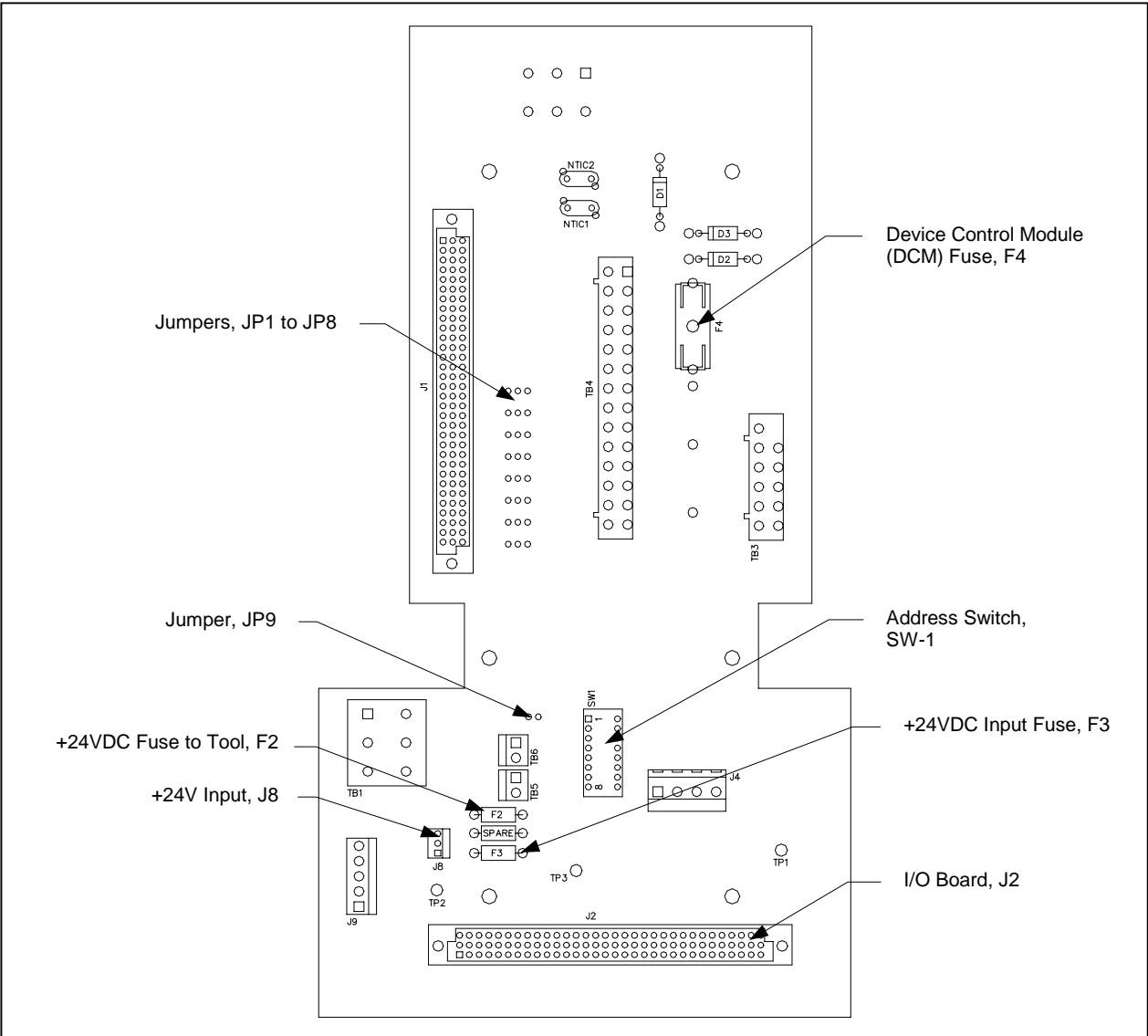

Figure 3-8. CS4000 Mini Controller with Ethernet Backplane

### ***Backplane Fuses***

Fuse F4 is Littelfuse 239001, 5x20 mm, 1A, SLO BLO (SB) 250V (part number 13-10-61001). Fuse F4 protects the DCM board inside the TCM.

Fuses F2 and F3 are Littelfuse 255.500, subminiature 0.5A (part number 13-10-4050). Fuse F2 protects the 24VDC to the tool, and Fuse F3 protects the 24VDC used with the discrete I/O circuits.

### ***Address Switches***

Each TCM has a unique serial address. The first six DIP switches on the address switch, SW-1, allow you to set up the communication address, 1 to 32, for the TCM.

Switch 7 assigns the baud rate at which the TCM sends data to an attached computer. When switch 7 is in the OFF position, a baud rate of 9600 kbps is used. When switch 7 is in the ON position, a baud rate of 57600 kbps is used. Switch 8 is used to set up the TCM for the "PFCS" Mode used by the DaimlerChrysler Plant Floor Communication System.

### I/O Board

The I/O board shown in Figure 3-9 is inserted into a connector, J2, on the backplane. It interfaces to all of the connectors available on the bottom of the controller, see Figure 3-3 on page 3-4. On the top side of the I/O board are some diagnostic connections (J19 and J20) for digital I/O.

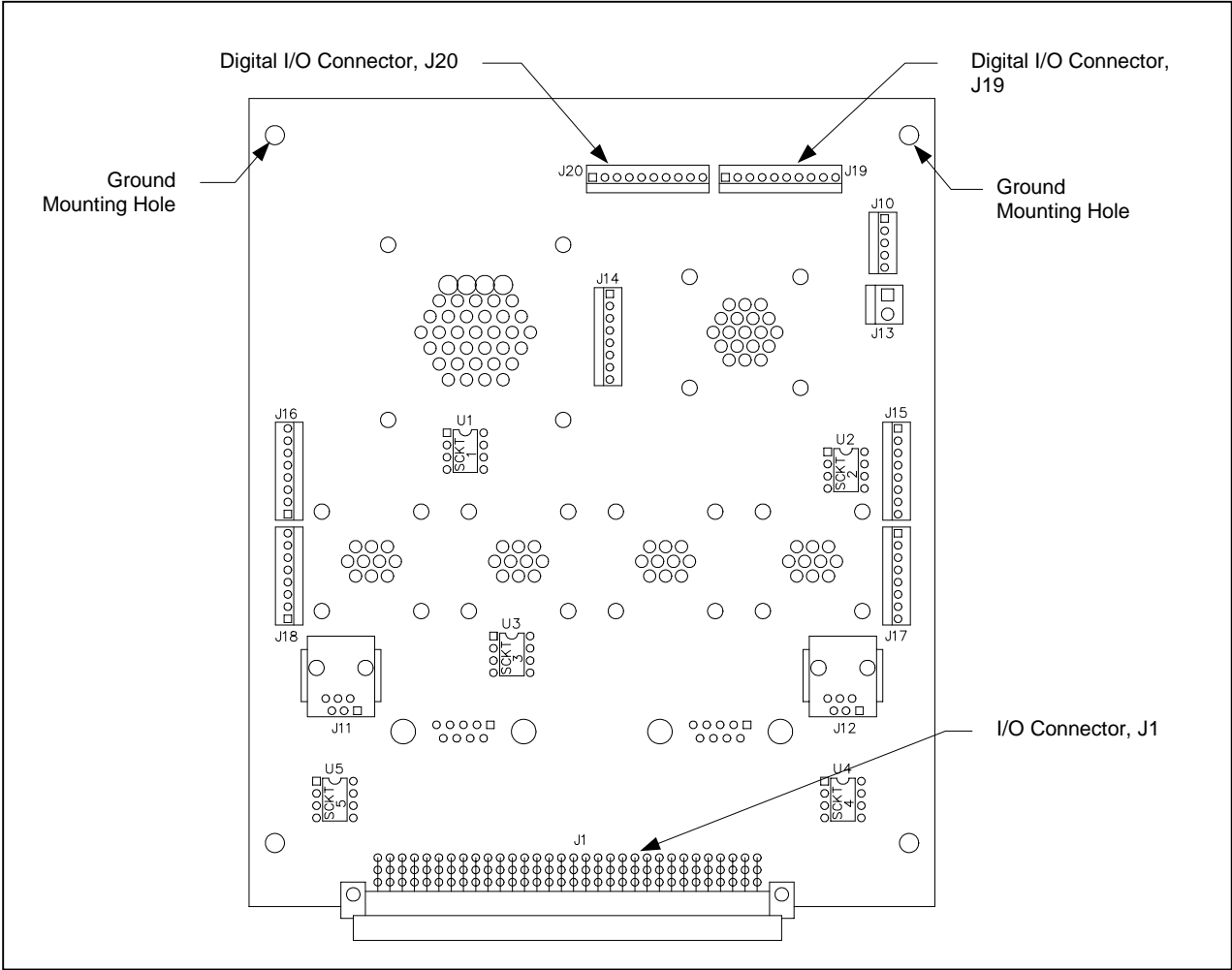

Figure 3-9. I/O Board

### Power Supply

A 1.2A, 24V power supply provides power for the TCM I/O and Ethernet interface card.



## Ethernet Interface Card

The Ethernet interface card (part number 420959-38093) is a printed circuit board into which internal component cables of the Ethernet network are plugged. It requires a 1A, 5V power supply that it draws from the 24VDC power supply inside the controller and converts to the necessary voltage.

The Ethernet interface card lets you connect individual controllers to a host device forming a LAN, using TCP/IP. The card comes with its own software and fits into the interior of the CS4000 Mini Controller with Ethernet, forming a connection with the Ethernet connector on the bottom panel of the controller. To attach to the Ethernet network, you need an Ethernet connector on the computer that will be the host, and an Ethernet cable with RJ-45 modular jacks attached to both ends. One of these RJ-45 modular jacks plugs into the Ethernet connector on the PC and the other plugs into the Ethernet connector on the controller.

Figure 3-10 shows the Ethernet interface card and its sub-components.

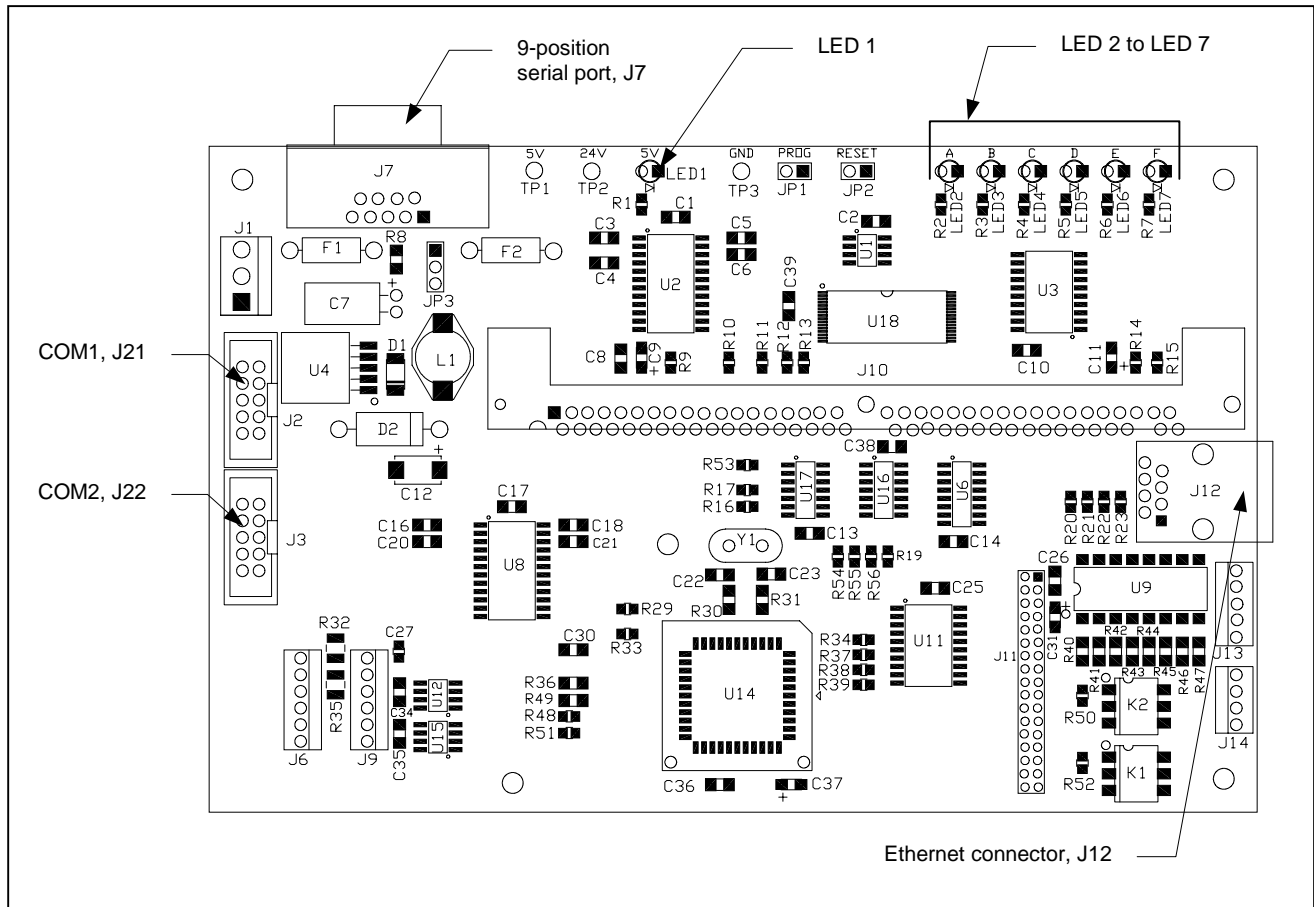

Figure 3-10. Ethernet Interface Card

The nine-position RS-232 serial port, J7, is used for setup and diagnostics of the Ethernet interface card. You can change the Ethernet application program or the TCP/IP information by using TINI Ethernet Interface Flash Utility on a laptop connected to the Ethernet interface card, via J7. Refer to *Chapter 4. Installing the CS4000 Mini Controller with Ethernet* for further details.

You can also obtain diagnostics information on the state of the Ethernet network through the Ethernet interface card using Hyperterminal. Refer to *Chapter 8. Maintenance/Troubleshooting* for further details.

Table 3-1 describes the LEDs on the Ethernet interface card. Each LED lights up steadily or flashes to indicate the current state of I/O connections.

**Table 3-1. Description of Ethernet Interface Card LEDs**

LED Name	Description
LED1 (5V)	Steady red light indicates the power supply is connected to the Ethernet interface card.
LED2 (A)	Flashing red light indicates communication between the controller and the host device of the Ethernet LAN using the Application Program Interface (API).
LED3 (B)	Flashing red light indicates Visual Supervisor communication between the controller and the host device of the Ethernet LAN.
LED4 (C)	Flashing red light indicates local Visual Supervisor communication between the controller and any PC that is attached to it, via an RS-232 connection.
LED5 (D)	Flashing red light indicates communication (Siemens 3964R) between the controller and the scanner using the RS-422 communications port.
LED6 (E)	Flashing yellow light indicates communication between the Ethernet interface card and the TCM.
LED7 (F)	Steady green light indicates successful power up initialization of the Ethernet interface card software.

## Interbus-S Module

The Interbus-S digital I/O module (part number 41-30-0300) is optional and is supplied only when it is specified at the time of order. When it is included in the controller enclosure, it provides another I/O interface, usually to an external, remote PLC. The module is housed inside the CS4000 Mini Controller with Ethernet enclosure. See Figure 3-4 on page 3-7.

Figure 3-11 shows the position of LEDs on the side of the Interbus-S module. Each LED lights up steadily to indicate the current state of I/O connections.

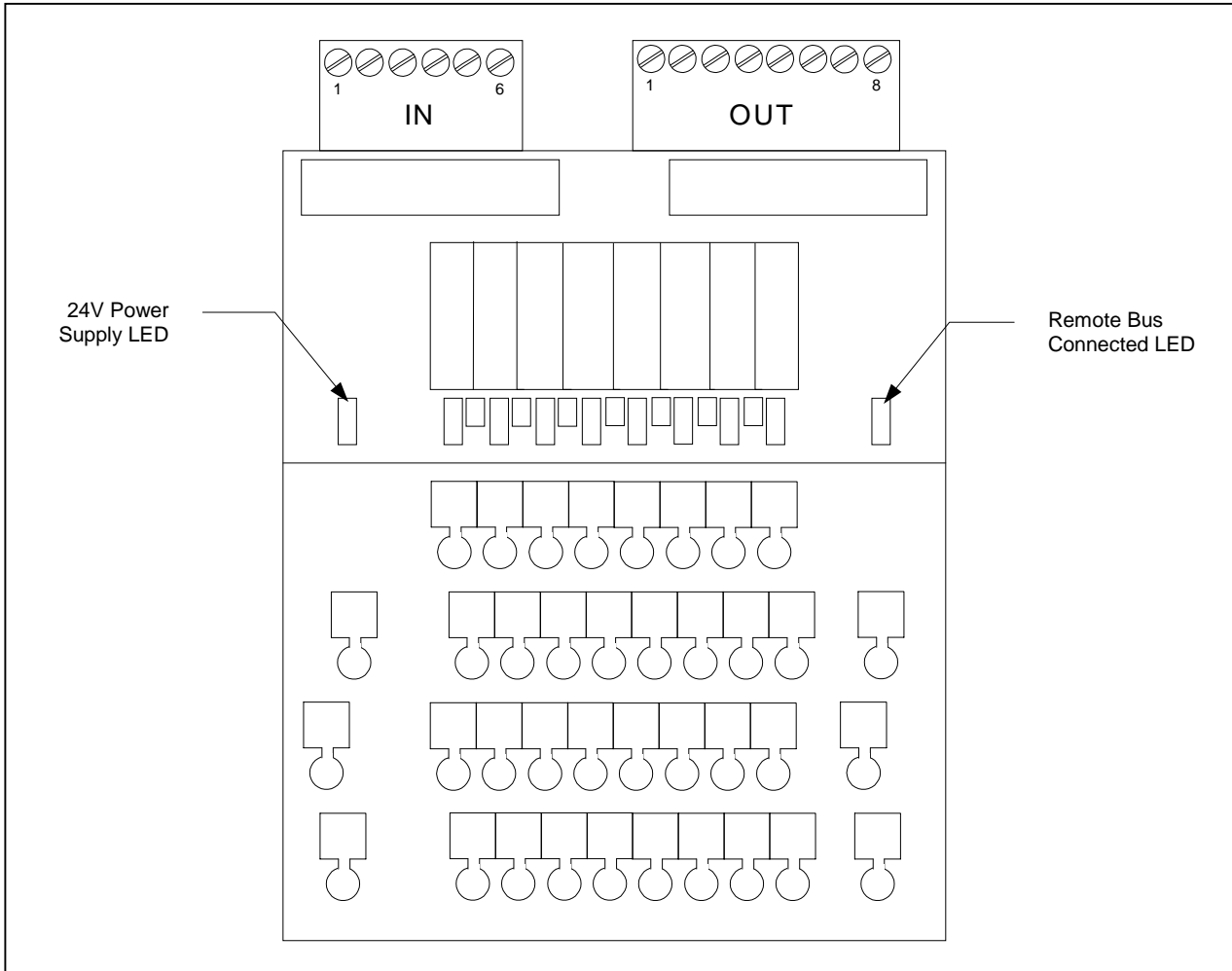

Figure 3-11. Interbus-S Module Side View

Table 3-2 describes the LEDs.

**Table 3-2. Description of LEDs on the Side of the Interbus-S Module**

LED Name	Description
<b>24V Power Supply</b>	Steady yellow light indicates the +24V power supply is connected to the Interbus-S module.
<b>Remote Bus Connected</b>	Steady green light indicates the remote bus is connected.

Figure 3-2 shows the position of the six-pin input terminal, nine-pin output terminal and LEDs on the top of the Interbus-S module. Each LED lights up steadily to indicate the current state of I/O connections.

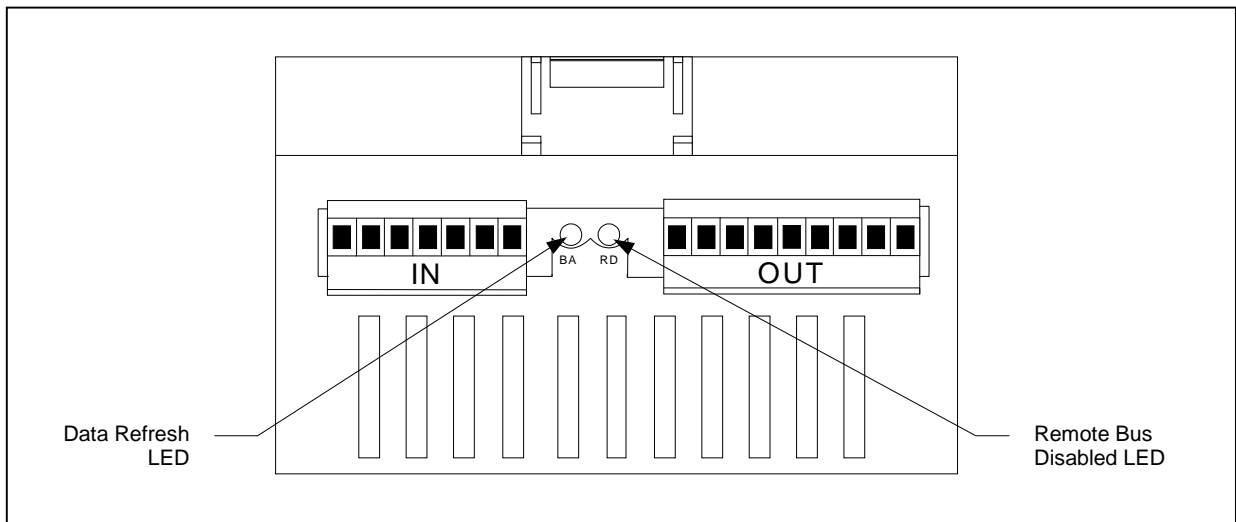

**Figure 3-12. Interbus-S Module Top View**

Table 3-3 describes the LEDs.

**Table 3-3. Description of LEDs on the Top of the Interbus-S Module**

LED Name	Description
<b>Data Refresh (BA)</b>	Steady green light indicates data is being refreshed.
<b>Remote Bus Disabled (RD)</b>	Steady red light indicates the remote bus is disabled.

## Ground Fault Circuit Interrupter

The Ground Fault Circuit Interrupter (GFCI) is wired in series from the AC power input to the servo amplifier. It monitors both AC power leads to the servo amplifier, ensuring that current flowing in one lead is the same as the current flowing out the other lead. If, due to a ground fault, the GFCI detects a net difference in the AC power exceeding 30 milliamps (30mA or .300 Amps), it shuts off the AC power to the servo amplifier automatically.

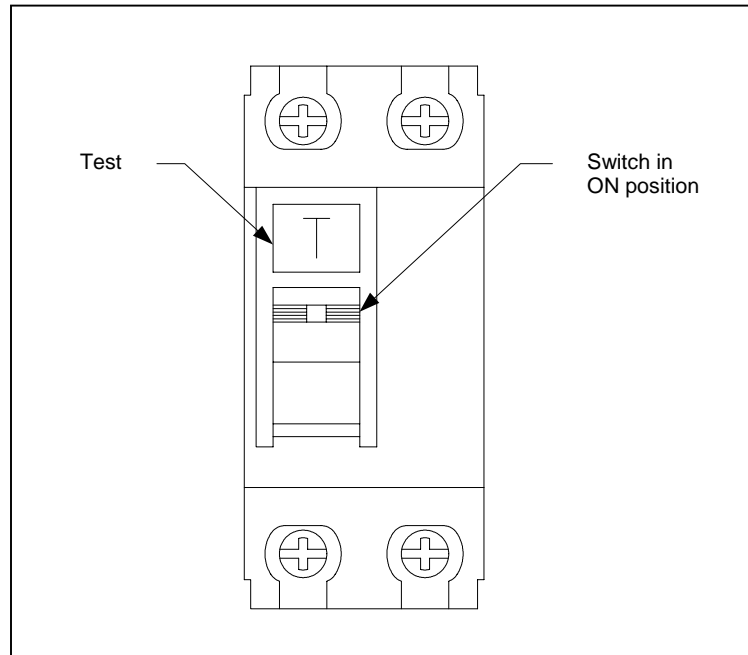

Figure 3-13. Ground Fault Circuit Interrupter

## Fuses

The main power fuses use a 15A, 250V, SLO-BLO Littelfuse 326015 or equivalent (part number 13-10-1015).

# 4. Installing the CS4000 Mini Controller with Ethernet

This chapter shows you how to mount and wire the CS4000 Mini Controller with Ethernet.

## Mounting the CS4000 Mini Controller with Ethernet

The CS4000 Mini Controller with Ethernet is installed vertically with the back flat against the mounting surface. Allow sufficient space around the controller to attach the power cable, tool cable, I/O cable and printer cable. Also be sure to allow space to remove the cover from the enclosure.

***CAUTION! Mount the CS4000 Mini Controller with Ethernet away from moving machinery and lift trucks on a structure that does not vibrate. Do not mount the CS4000 Mini Controller with Ethernet near large electrical systems, motors, welding equipment, or in an area of temperature or moisture extremes.***

Figure 4-1 shows the dimensions and mounting holes on the CS4000 Mini Controller with Ethernet.

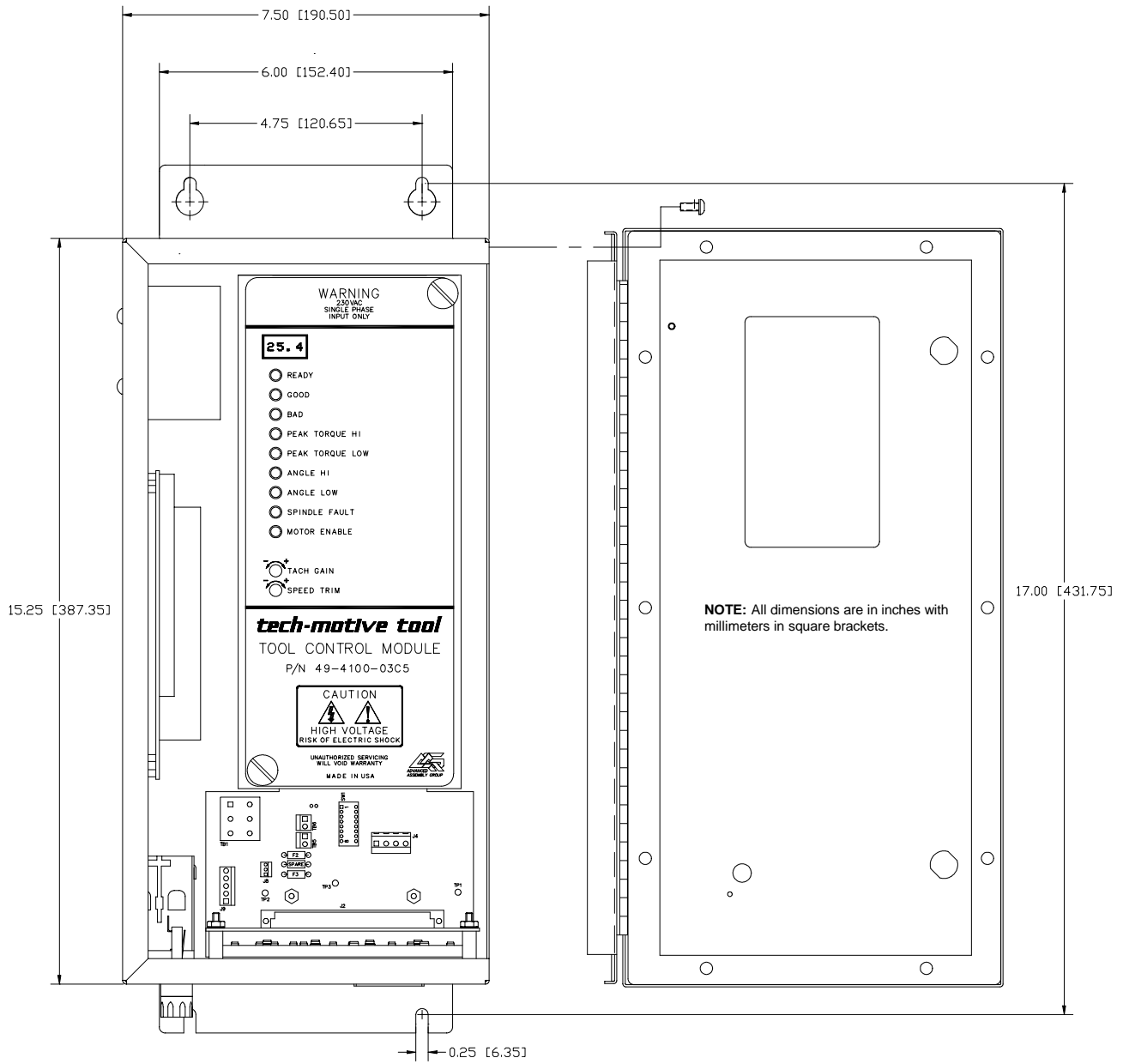

Figure 4-1. CS4000 Mini Controller with Ethernet Dimensions

To mount the controller you require four 1/4-20-in bolts or screws.

# Power and Connection-Requirements

**WARNING! 230 VAC SINGLE PHASE INPUT ONLY. Internal capacitors store a high voltage charge and discharge slowly after external power is removed.**

Figure 4-2 shows the power supply and connection requirements of the CS4000 Mini Controller with Ethernet.

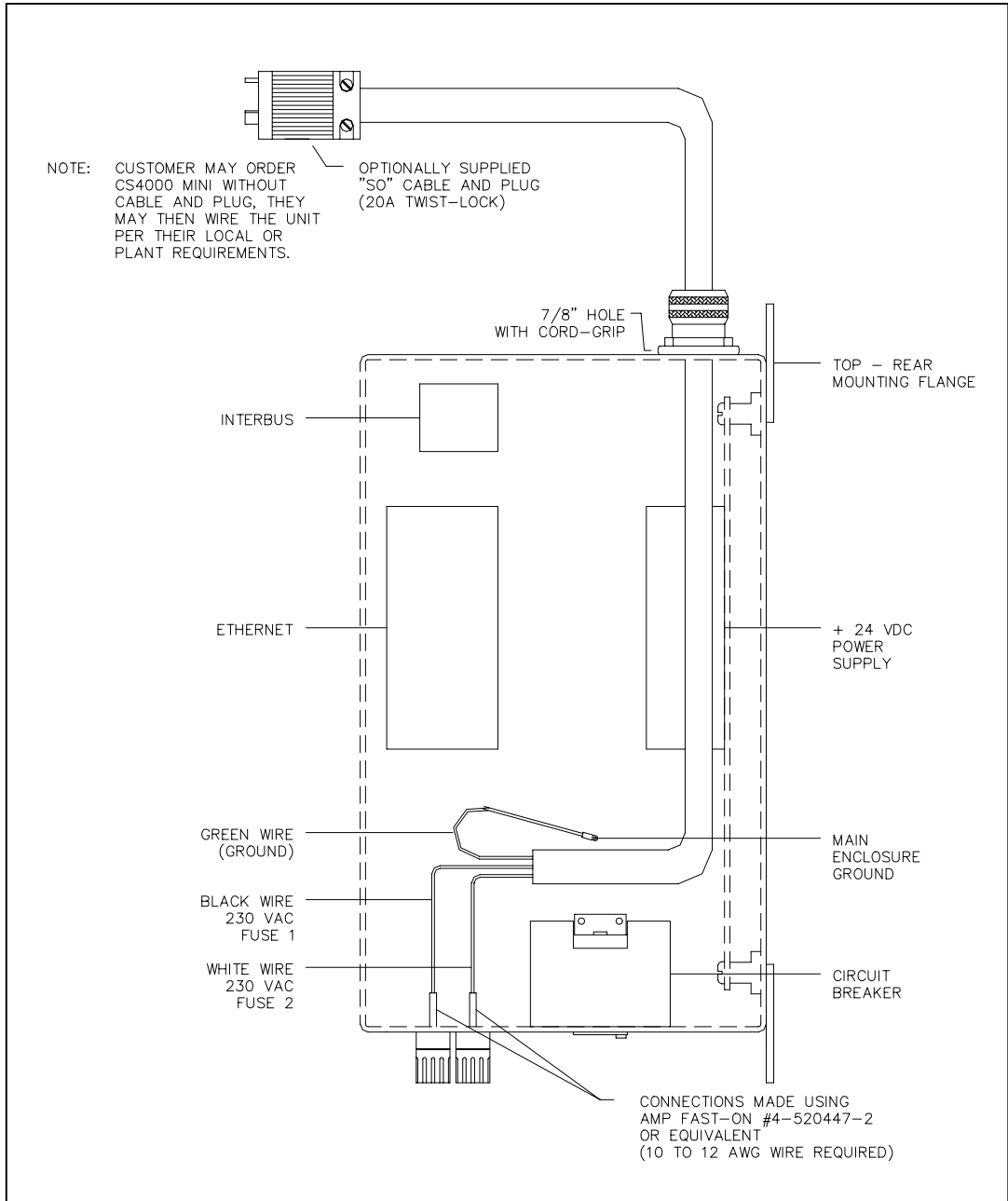

Figure 4-2. Power/Connection Requirements



## Meeting the AC Input Power Requirements

**CAUTION!** *Failure to provide the proper power source can cause the following problems in your CS4000 Mini Controller with Ethernet:*

- *The nutrunner might shut down before it reaches the target torque during a rundown cycle.*
- *The nutrunner might not turn when a cycle-on signal is applied to the system.*
- *The maximum free speed of the nutrunner might be lower than specified.*

For proper operation, especially during peak power draw periods, be sure to connect the CS4000 Mini Controller with Ethernet to a clean source of AC power that is capable of maintaining the specified line voltage under the required load conditions. If the AC line is subject to frequent over-voltage and under-voltage conditions, some type of power line conditioning will be required.

*NOTE: The maximum no-load speed of all tech-motive tool nutrunners is based on an AC input voltage of 230V; if the actual input voltage is lower, the maximum no load speed of the nutrunner will be lower than specified.*

It is recommended that the input voltage be between 208 and 250 VAC (single phase). A power source capable of delivering 1 to 1.5 kVA should be sufficient in most applications.

## Grounding

**WARNING!** *The Ground Fault Circuit Interrupter cannot protect you against any potential difference that exists between the nutrunner body and any other metal fixturing or machinery. You must observe the grounding requirements below as a safety protection.*

It is *extremely* important that you connect the CS4000 Mini Controller with Ethernet enclosure properly to an earth ground. The CS4000 Mini Controller with Ethernet has a ground prong on the power cord, (if supplied) but the AC outlet that will be used must be grounded properly, as well.

Also make sure that all other machinery, such as conveyors, which will transport or hold parts that will come in physical contact with the nutrunner, are properly grounded.

## I/O Wiring

The CS4000 Mini Controller with Ethernet is equipped with a 19-pin I/O connector for field I/O. The settings described in Table 4-1 are Visual Supervisor (VS) default settings.

*NOTE: The 14-shell, 19-pin strain relief mating connector for the I/O connector is part number 23-10-5200.*

**Table 4-1. 19-Position Remote I/O Connector Pinout Signal Names and Descriptions**

Pin	Signal	Description
A	<b>Cycle On/Cycle On Enable Clear Outputs (Black wire - internal) (Black wire - external)</b>	<p>This is a dual-purpose input.</p> <p>When Set Defaults is clicked, VS sets this input to <i>Start</i>, this input functions as a <i>cycle on</i> input. This means a fastening cycle can be started by either pressing the throttle/trigger switch on the nutrunner OR by activating this input.</p> <p>When remote mode for the spindle is set to <i>enable</i>, this input functions as a <i>cycle on enable</i> input. This means a fastening cycle can be started only by pressing both the throttle/trigger switch on the nutrunner and activating this input.</p> <p>In addition, it is also set to Clear Outputs.</p> <p>This is a level-sensitive input. For the fastening cycle to proceed, this input must remain active. If this input becomes inactive at any time during the fastening cycle, the cycle will be aborted and the nutrunner will stop running.</p>
B	<b>Forward/Reverse input (White wire internal) (White wire - external)</b>	<p>When Set Defaults is clicked, VS sets this input to the direction the nutrunner turns in a fastening cycle:</p> <p>If this input is active when a fastening cycle is started, the nutrunner will run in the forward (fastening or tightening) direction. If this input is inactive when a fastening cycle is started, the nutrunner will run in the reverse (un-fastening or loosening) direction.</p> <p>After a fastening cycle has started, changing the state of this input has no effect on the fastening direction until the cycle on command (from either the nutrunner or the cycle on input or both) is de-activated. This means the input must be in the desired state BEFORE activation of the cycle start input.</p>
C	<b>Discrete Input #7 (Gray wire - internal) (Red wire - external)</b>	Defaults to "Manual Calibration."
D	<b>Discrete Input #8 (Yellow wire - internal) (Green wire - external)</b>	Multi-purpose switch input "OR" function with switch on tool.

Table 3-1. 19-Position Remote I/O Connector Pinout Signal Names and Descriptions (Continued)

Pin	Signal	Description																																				
E	Limit Set Select B0 input (Red wire - internal) (Orange wire - external)	When Set Defaults is clicked, VS sets these three inputs to select which of the eight internal limit (or parameter) sets are used for a fastening cycle, as follows:																																				
F	Limit Set Select B1 input (Green wire - internal) (Blue wire - external)	<table border="1"> <thead> <tr> <th>Limit Set</th> <th>B2 Input</th> <th>B1 Input</th> <th>B0 Input</th> </tr> </thead> <tbody> <tr><td>1</td><td>inactive</td><td>inactive</td><td>inactive</td></tr> <tr><td>2</td><td>inactive</td><td>inactive</td><td>active</td></tr> <tr><td>3</td><td>inactive</td><td>active</td><td>inactive</td></tr> <tr><td>4</td><td>inactive</td><td>active</td><td>active</td></tr> <tr><td>5</td><td>active</td><td>inactive</td><td>inactive</td></tr> <tr><td>6</td><td>active</td><td>inactive</td><td>active</td></tr> <tr><td>7</td><td>active</td><td>active</td><td>inactive</td></tr> <tr><td>8</td><td>active</td><td>active</td><td>active</td></tr> </tbody> </table>	Limit Set	B2 Input	B1 Input	B0 Input	1	inactive	inactive	inactive	2	inactive	inactive	active	3	inactive	active	inactive	4	inactive	active	active	5	active	inactive	inactive	6	active	inactive	active	7	active	active	inactive	8	active	active	active
Limit Set	B2 Input	B1 Input	B0 Input																																			
1	inactive	inactive	inactive																																			
2	inactive	inactive	active																																			
3	inactive	active	inactive																																			
4	inactive	active	active																																			
5	active	inactive	inactive																																			
6	active	inactive	active																																			
7	active	active	inactive																																			
8	active	active	active																																			
G	Limit Set Select B2 input (Orange wire - internal) (White/Black wire - external))	After a fastening cycle has started, changing the state of these inputs does not change which limit set the CS4000 Controller uses until the cycle on command (from either the nutrunner or the cycle on input or both) is de-activated. This means these inputs must be in the desired state BEFORE activation of the cycle start input.																																				
H	CS4000 +24 VDC (Blue wire - internal) (Red/Black wire - external))	This pin (and pin T) is connected to the positive (+) terminal of the internal 24VDC I/O power supply and is normally used as the common connection for the input signals.																																				
J	Discrete output #1* (White/Black wire - internal) (Green/Black wire - external)	Pins J, K, L, M, N, P, and U are the programmable discrete outputs.																																				
K	Discrete output #2* (White/Red wire - internal) (Red/Black wire - external)	Any one of these outputs will become active when its programmed																																				
L	Discrete output #3* (White/Green wire - internal) (Blue/Black wire -external)	Output function becomes true. When Set Defaults is clicked, VS sets these outputs to:																																				
M	Discrete output #4* (White/Violet wire - internal) (Black/White wire - external))	J = Cycle Finish, K = Cycle good, L = Cycle bad, N = In Cycle.																																				
N	Discrete output #5* (White/Blue wire - internal) (Red/White wire - external)																																					
P	Discrete output #6 (White/Gray wire - internal) (Green/White wire - external)																																					

Table 3-1. 19-Position Remote I/O Connector Pinout Signal Names and Descriptions (Continued)

Pin	Signal	Description
R	<b>Synchronization in/out</b> (White/Orange wire - internal) (Orange/Red wire - external)	<p>This bi-directional signal is used for synchronizing two or more spindles in a multi-spindle fastening application. It is connected to both the synchronization output (Discrete output #8) and the synchronization input (Discrete input #6).</p> <p>If Sync is set to <i>On</i>, the synchronization output becomes active when a fastening cycle is started. When the nutrunner output torque reaches the Control Reference level, the synchronization output is de-activated. At the same time, the state of the synchronization input is sampled. If it is still active because some other spindle has not reached the synchronization level yet, it stops the nutrunner and waits for the synchronization input to become inactive. Afterwards, it re-starts the nutrunner and finishes the fastening cycle.</p> <p>This pin should be connected to the synchronization in/out pin of all other spindles for which synchronization is desired.</p> <p><b>NOTE: This feature only functions when JP8 and JP9 are set to defaults.</b></p>
S	<b>Output common</b> (White/Brown wire - internal) (Blue/white wire - external)	This pin is connected to the negative terminal (-) of the internal 24VDC I/O power supply and is normally used as the common connection for the output signals.
T	<b>CS4000 +24 VDC</b> (Blue wire - internal) (Black/Red wire - external)	This pin (and pin <i>H</i> ) is connected to the positive (+) terminal of the internal 24VDC I/O power supply and is normally used as the common connection for the input signals.
U	<b>Discrete output #7*</b> (Brown wire - internal) (White/Red wire - external)	Pins <i>U</i> and <i>J, K, L, M, N, and P</i> are the programmable discrete outputs. Any one of these outputs will become active when its programmed output function becomes true. The functions of these outputs are set with VS set output.
V	<b>Synchronization common</b> (Violet wire - internal) (Blue/Red wire - external)	This is the common connection for the synchronization input/output. It should be connected to the synchronization common pin of all other spindles for which synchronization is desired.

\*Early units have these outputs fixed in the software. Units with KDM software 2.5 or later have configurable outputs.

**NOTE:** Active means an input is connected to +24VDC. Inactive means an input is either not wired or is wired to common.

A remote input circuit schematic and remote I/O schematics for sourcing and sinking outputs are shown in Figure 4-3 through Figure 4-5.

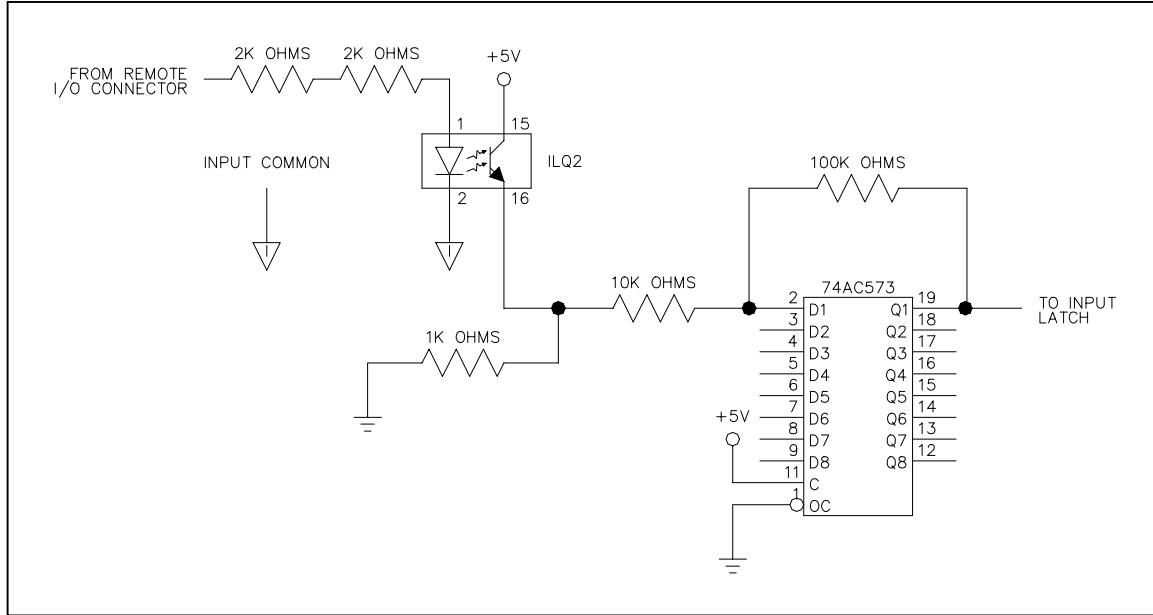

Figure 4-3. Remote Input Circuit Schematics

To ensure that you operate the fastening system properly, refer to Table 4-2 for input requirements.

Table 4-2. Guidelines for Proper Operation of the Controller I/O Signals

Discrete Inputs		Unit
	Highest permissible input voltage	30 V
	Lowest permissible input voltage	-5 V
	Minimum guaranteed input activation	10 V
	Maximum guaranteed input activation	1.5 V
Discrete outputs		Unit
	Maximum output current	360 mA
	Maximum voltage	28 Volts DC

Figure 4-4 is an example of the remote I/O wiring scheme using the defaults (voltage source) for the jumpers. It shows one of the many ways the remote I/O feature of the controller can be used. To ensure that you operate the fastening system properly, refer to Table 4-2 for output requirements. See Figure 3-8 on page 3-11 for the locations of JP1 to JP9 on the backplane.

**NOTE: JP9 ties discrete output 8 to discrete input 6 for spindle synchronization.**

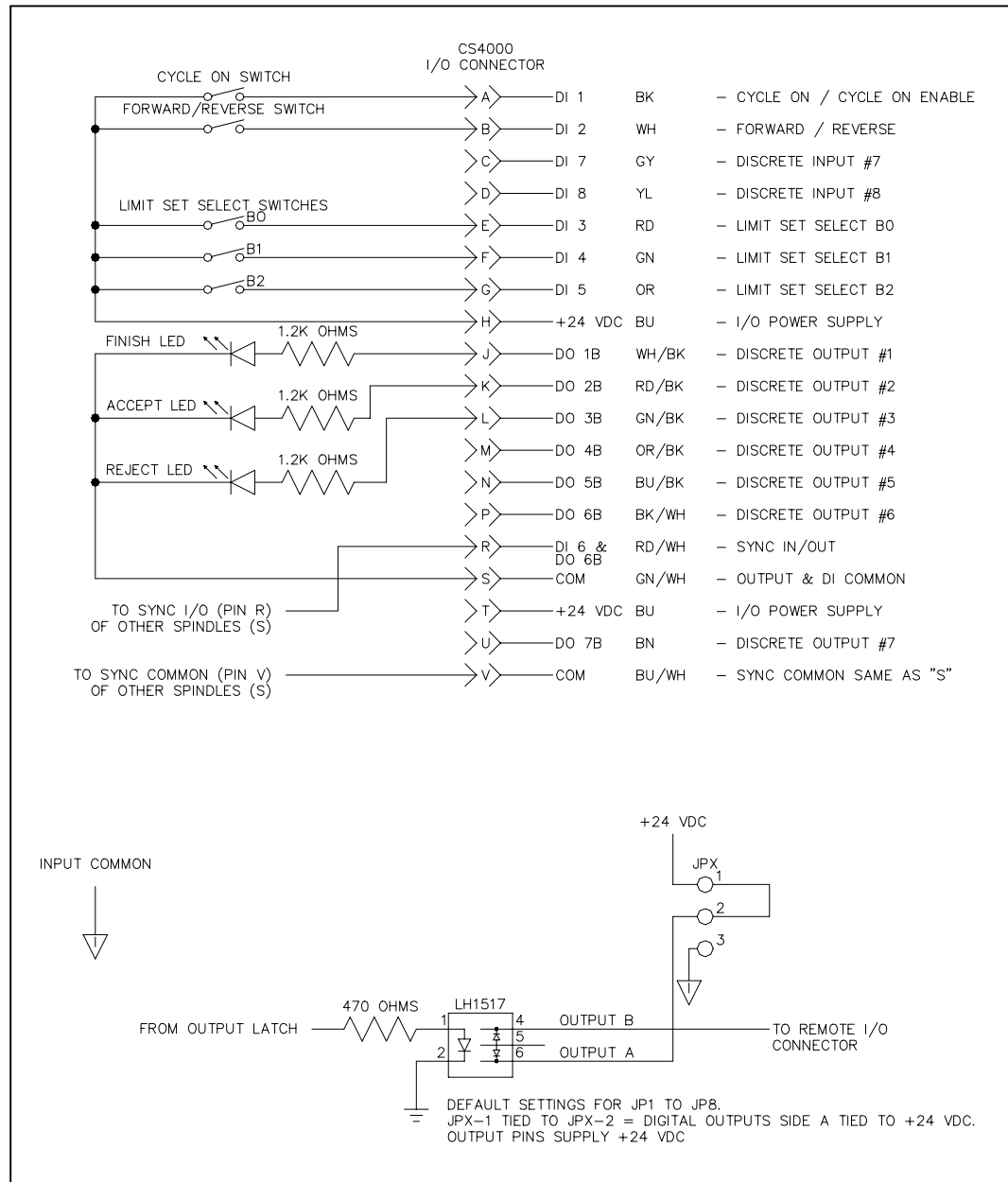

Figure 4-4. Example of CS4000 Controller Remote I/O Wiring – Sourcing Outputs

Figure 4-5 is an example of the remote I/O wiring scheme that shows how to change the jumpers for voltage sink. It shows one of the many ways the remote I/O feature controller can be used. To ensure that you operate the fastening system properly, refer to the guidelines in Table 4-2 for output requirements. The locations of jumpers JP1 to JP9 are important, see Figure 3-8 on page 3-11 for their locations on the backplane. The jumpers allow you to select between +24V DC applied to an output or ground applied to an output. To change to voltage sink configuration cut trace from pin 1 to 2 and solder in place a jumper between pins 2 and 3 to take the I/O pin to ground.

**NOTE: JP9 ties discrete output 8 to discrete input 6 for spindle synchronization.**

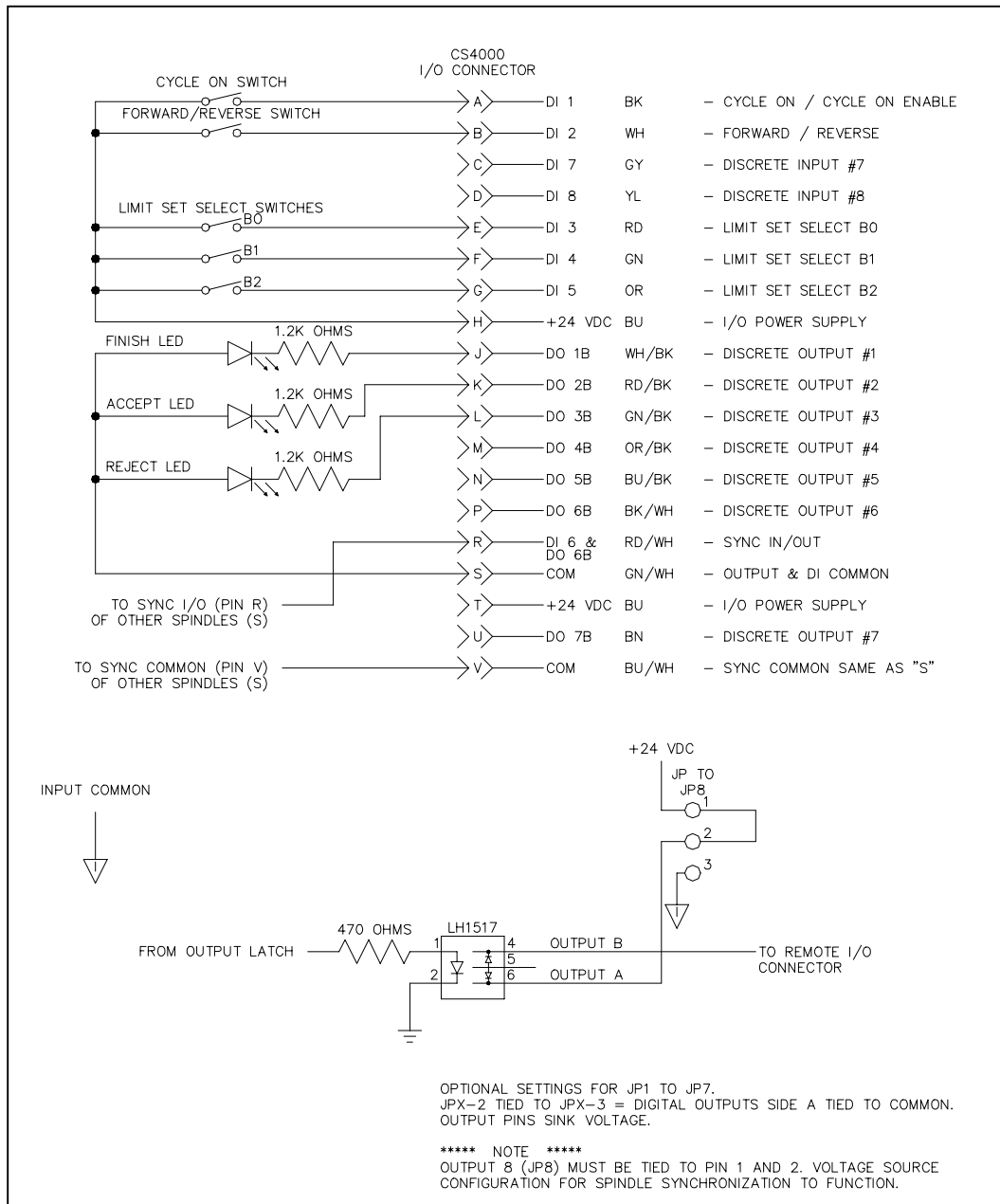

Figure 4-5. Example of CS4000 Controller Remote I/O Wiring – Sinking Outputs

## Connector Pinout Definitions

Pinout definitions are provided for the tool, I/O, RS-422, TCM network, RS-232, printer/barcode and Interbus-S connectors.

### Tool Connector

Pin Designation	Wire Color (Ref)	Function
1	WHT	POWER PHASE 1
2	RED	POWER PHASE 2
3	BLK	POWER PHASE 3
4	GRN/YEL	TOOL GROUND/SHIELD
10	GRN	SHIELD
13	ORN	SHIELD
14	BR/WHT	CLOCK +
15	WHT/BRN	CLOCK -
16	GRN/WHT	RXD +
17	WHT/GRN	RXD -
21	BLU/WHT	TXD +
22	WHT/BLU	TXD -
27	ORN/WHT	+ 24V
28	WHT/ORN	24V RET.
Nos. not listed	--	No connection

### I/O Connector

Pin Designation	Wire Color (Ref)	Function
A	BLK	CYCLE ON INPUT
B	WHT	FORWARD/REVERSE INPUT
C	GRY	DISCRETE INPUT #7
D	YEL	DISCRETE INPUT #8
E	RED	LIMIT SET SELECT B0 INPUT
F	GRN	LIMIT SET SELECT B1 INPUT
G	ORN	LIMIT SET SELECT B2 INPUT
H	BLU	+24V INPUT
J	WHT/BLK	DISCRETE OUTPUT #1 (FINISHED)
K	WHT/RED	DISCRETE OUTPUT #2 (ACCEPT)
L	WHT/GRN	DISCRETE OUTPUT #3 (REJECT)
M	WHT/YEL	DISCRETE OUTPUT #4
N	WHT/BLU	DISCRETE OUTPUT #5
P	WHT/GRY	DISCRETE OUTPUT #6
R	WHT/GRN	SYNC IN/OUT
S	WHT/BRN	OUTPUT COMMON
T	BU	+24V
U	BRN	DISCRETE OUTPUT #7
V	VIO	SYNC COMMON

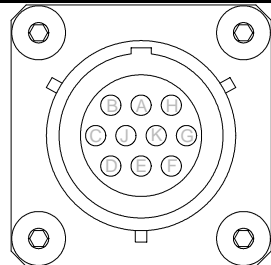

## RS-422 Connector

	Pin Designation	Wire Color (Ref)	Function
	A	BRN/WHT	TXD+ OUT
	B	WHT/BRN	TXD- OUT
	C	ORN/WHT	RXD+ IN
	D	WHT/ORN	RXD- OUT
	E	GRN/WHT	Not used
	F	WHT/GRN	Not used
	G	BLU/WHT	SHIELD COMMON
	H	GRN	SHIELD

## Tool Control Module (TCM) Network Connector

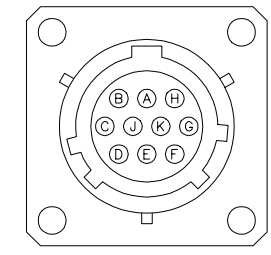
	Pin Designation	Wire Color (Ref)	Function
	A	BRN/WHT	TXD+ OUT
	B	WHT/BRN	TXD- OUT
	C	ORN/WHT	RXD+ IN
	D	WHT/ORN	RXD- OUT
	E	GRN/WHT	CLK+ OUT
	F	WHT/GRN	CLK- OUT
	G	BLU/WHT	SHIELD COMMON
	H	GRN	SHIELD

## RS-232 Connector

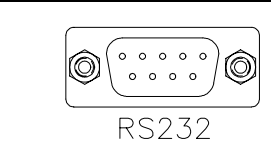
 <p>RS232</p>	Pin Designation	Wire Color (Ref)	Function
	2	BLU	RXD
	3	GRN	TXD
	5	BLK	GND
	7	RED	RTS
	8	YEL	CTS

## Printer/Barcode Connector

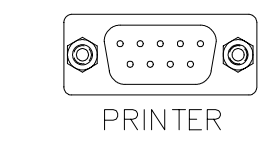
 <p>PRINTER</p>	Pin Designation	Wire Color (Ref)	Function
	2	BLU	RXD
	3	GRN	TXD
	5	BLK	GND
	7	RED	RTS
	8	YEL	CTS

## Interbus-S “IN” Connector

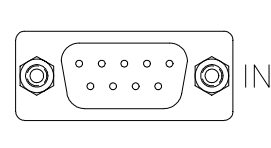
 <p>IN</p>	Pin Designation	Wire Color (Ref)	Function
	1	YL	DO1
	2	GY	DI1
	3	BRN	GND1
	6	GRN	Not DO1
	7	PK	Not DI1

## Interbus-S “OUT” Connector

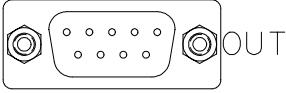
	Pin Designation	Wire Color (Ref)	Function
	1	YL	DO2
	2	GY	DI2
	3	BRN	GND1
	5	RD	+5V
	6	GRN	Not DO2
	7	PK	Not DI2
	9	WH	RBST

(This page is left blank intentionally.)

# 5. Setting Up the Ethernet

The CS4000 Mini Controller with Ethernet can be connected to an Ethernet Local Area Network (LAN). This chapter describes the steps you must take to set up the Ethernet LAN:

- Programming the Ethernet interface card
- Setting up Visual Supervisor for networks
- Using Ethernet cables
- Testing the network

## Programming the Ethernet Interface Card

The Ethernet interface card, shown in Figure 3-10 on page 3-14, has its own firmware. You must install this software on to the card before attempting to connect the controllers via the Ethernet.

To program the Ethernet interface card, you require:

- Pentium class laptop computer.
- Microsoft Windows 95, 98, 2000, or Windows NT version 4.0 or above.
- At least 64 MB RAM for Windows 95, 98, 2000 or 128 MB for Windows NT.
- Null modem cable with female-to-female connectors.
- TINI Ethernet Interface Flash Utility (Etherflash), version 1.2.

*NOTE: Before programming the Ethernet interface card, it is recommended that you make a note of its IP address and subnet mask settings. If you do not know the IP address or subnet mask setting, use the TINI Ethernet Flash Utility to read them. Refer to Procedure 5-2 on page 5-10 for details.*

## Working with the IP Address, Subnet Mask and Default Gateways

The **Internet Protocol (IP) address** identifies each individual device on a network. It is read by router software which directs information across the network. The computer that controls the flow of data in and out of a company's network is the gateway between the company network and any other networks attached to it. Sometimes, you may need to know the IP address of the gateway computer as well - often referred to as the **default gateway**.

Without a correct IP address for each device on the network, and a subnet mask if the network is divided into smaller sections called subnetworks, the Ethernet network cannot function correctly. In the case of a controller, the IP address identifies the position of that specific controller on the local area network (LAN) and it is needed to successfully transfer data in and out of the controller across the network.

The IP address consists of 32-bits (Internet Protocol version 4, IPv4) and is most often depicted in a dot address. This is the format in which you must enter IP addresses for the CS4000 Mini Controller with Ethernet software. It is called a dot address because the address is divided into four groups of decimal digits separated by a period. Each group of decimal digits represents a much longer binary number. For example:

10.1.100.146

Many organizations divide their networks into sub-networks. The sub-network is identified in a section of the IP address and the **subnet mask** specifies which part of the IP address contains the address of the sub-network. The subnet mask is read by the router software. The subnet mask is specified in the same format as the IP address, but here it is informing the router software that reads the IP address which part of the address holds the subnetwork identifier. For example:

255.255.255.0

In the above example '255' represents a binary number of '1' which tells the router software reading the address that this is the combined network and subnetwork section of the IP address. The '0' represents a binary number that is also '0' and it tells the software reading the address not to look at the final part of the address that identifies a specific device. When the information reaches the specified subnetwork, then the final part of the IP address is read to identify the final destination, in this case, the individual controller or computer attached to the Ethernet network.

In the case of the Ethernet interface card installed inside the CS4000 Mini Controller with Ethernet, the IP address, subnet mask and default gateway are stored in the motherboard to which the Ethernet interface card is attached. This allows you to transfer Ethernet interface cards from one controller to another controller without changing the IP address, subnet mask or default gateway of that controller. To change the IP address, subnet mask or default gateway, you change the value held in the motherboard by sending it the new values, via the Ethernet interface card. This process is called programming or flashing the Ethernet interface card.

You can use the TINI Ethernet Flash Utility to find and change the IP address, subnet mask and default gateway of a specific controller while programming (or flashing) an Ethernet interface card, or by using the Application Settings window. To find out how to use the Application Settings window, refer to Procedure 5-2 on page 5-10.

Use Procedure 5-1 to program (or flash) the Ethernet interface card.

---

### ***Procedure 5-1. Programming the Ethernet Interface Card***

---

1. Turn OFF power to the controller.

***WARNING! Make sure the power is OFF before you open the enclosure door. High voltage when the power is ON can result in electrical shock or electrocution, and also damage to the TCM inside the enclosure.***

2. Using a No.2 cross-tip (Phillips) head screwdriver, turn the access screws on the outside of the enclosure counterclockwise to loosen them. Finish removing them by hand.
3. Open the enclosure door and locate the Ethernet interface card housed inside the controller.

4. **Insert one of the female connectors on the null modem cable (part number 41-41-0109FN) into the 9-pin connector (J7) on the Ethernet interface card. See Figure 3-10 on page 3-14.**

As you open the enclosure door and look at the interior, the Ethernet interface card is mounted in the top left of the enclosure.

*NOTE: You do NOT need to remove the card from the enclosure to attach the null modem cable. The cable must be a full null modem GSE tech-motive tool cable; RJ-11 cable will not work.*

5. **Insert the other end of the null modem cable, which is also a female connector, into the RS-232 port on the laptop computer.**

It is recommended that you use the communications port, COM1. If, for some reason, this is not available, you may use any RS-232 port that is available. Make sure you know which COM port you are using.

6. **Install jumper, J1, labeled “Prog” on the Ethernet interface card.**

Pull the jumper off the Ethernet interface card, then carefully push the jumper on to pins 1 and 2.

7. **Turn ON power to the controller.**

8. **Start the TINI Ethernet Interface Flash Utility.**

The TINI Ethernet Interface Flash Utility is a program installed directly on to your laptop computer. To start the program, find the executable file *Etherflash.exe* and double click on it.

*NOTE: The flash utility can be run from a floppy disk drive. To do this, put the disk in the laptop floppy disk drive, select the drive using Windows Explorer and double click on the executable file Etherflash.exe.*

As soon as you start the program, a message appears in the TINI Ethernet Interface Flash Utility window, shown in Figure 5-1. This is the normal operation of the program and you can still proceed to the next step.

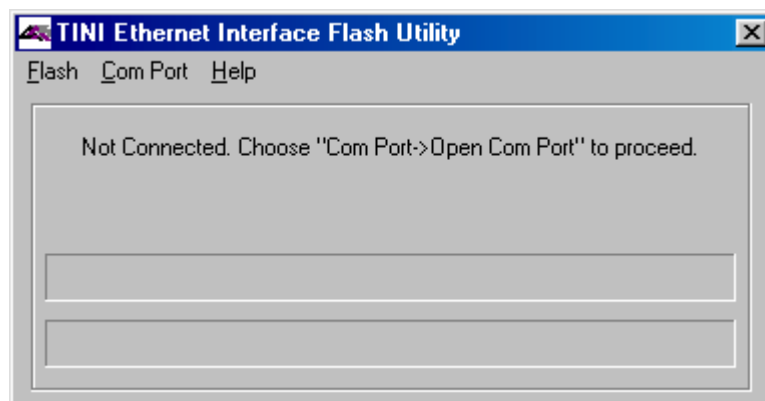

**Figure 5-1. Message Upon Starting the TINI Ethernet Interface Flash Utility**

9. Select the RS-232 serial communications port on your laptop that you will be using to send data to the attached Ethernet interface card.

This is the communications port to which the null modem cable is attached.

- a. Click the **Com Port** menu in the TINI Ethernet Flash Utility window. See Figure 5-2.

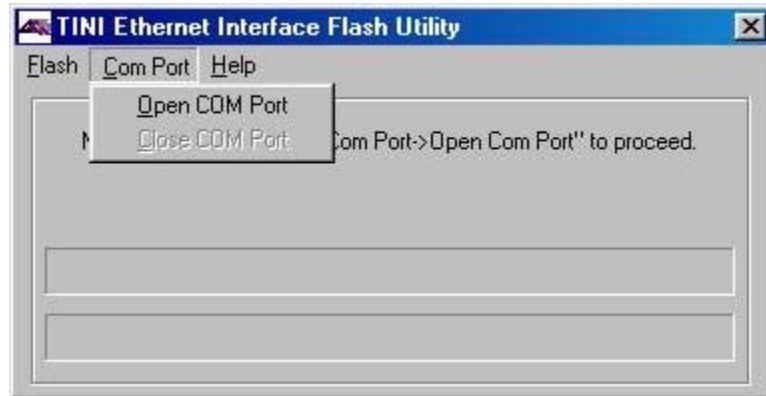

Figure 5-2. Selecting the COM Port Menu

- b. From the **Com Port** menu, select **Open COM Port**.
- c. In the Select COM Port to Open window, there is a drop-down list of communication ports that you can open, from COM1 to COM5. Select 'COM1' for your laptop computer. See Figure 5-3.

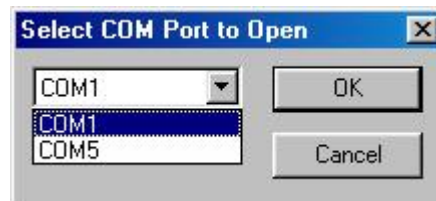
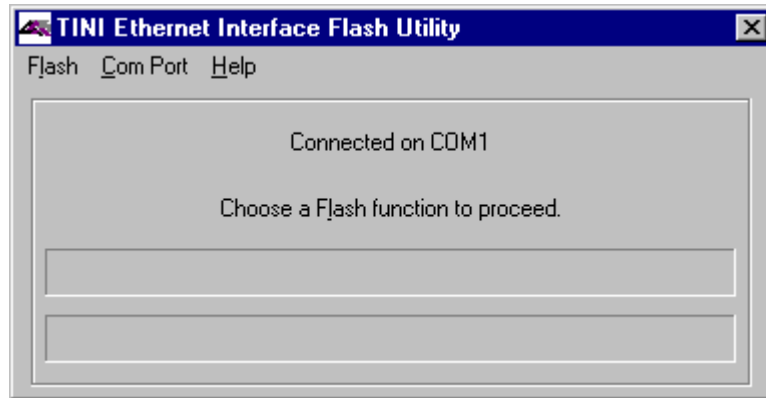

Figure 5-3. Selecting 'COM1' RS-232 Port

*NOTE: If, for some reason COM1 is unavailable, you may select a different communications port. If you do select a different port, make sure that the null modem cable is inserted into this port in Step 3. If you select a different communications port instead of COM1, then you will see that port substituted wherever you see 'COM1' written in this procedure.*

- d. Click **OK**.

The TINI Ethernet Interface Flash Utility attempts to connect to the communications port you specified in Step 9. When the attempt is successful, the message shown in Figure 5-4 is displayed.



**Figure 5-4. Establishing A Successful Connection via COM1**

When another utility or program is using the COM1 port, the attempt to establish a connection fails and the message shown in Figure 5-5 is displayed.



**Figure 5-5. Error Message Displayed when COM1 is Already In Use**

When you receive this error message, click **OK**, terminate any other utilities or programs that may be using the COM1 port and start this procedure again from Step 9.



**10. Flash the application file to the Ethernet interface card.**

- a. Click the **F**lash menu in the TINI Ethernet Interface Utility window.
- b. From the F<sub>l</sub>ash menu, click **F**lash TINI....

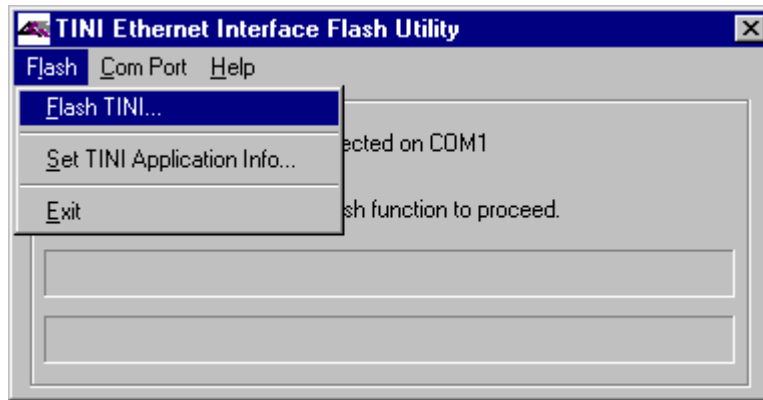
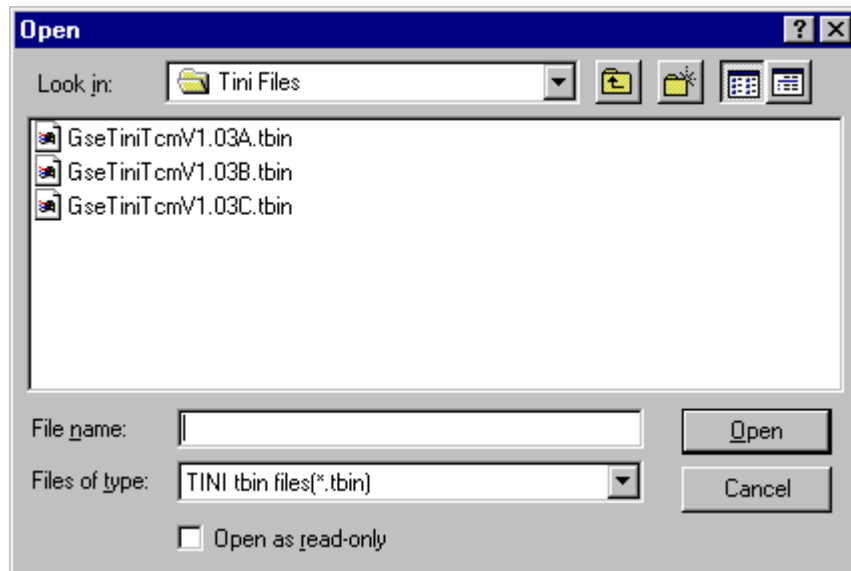

**Figure 5-6. Selecting the “Flash TINI...” Option**

**11. From the list of files displayed to you in the Open window, open the application file you want to use to flash the Ethernet interface card.**

The application file is a binary file that adheres to the following naming convention: *GseTiniTcmV9.99X.tbin*, where '9.99X' represents the version number of the application. For example, *GseTiniTcmV1.03C.tbin* is the binary file for version 1.03C of the application.

- a. Click on the application file displayed in the Open window. See Figure 5-7.
- b. Click **O**pen.



**Figure 5-7. Selecting the Application File**

The TINI Ethernet Flash Utility connects to the Ethernet interface card, via the COM port you specified in Step 9. When the communications connection is successful, the yellow LED (LED6 on the Ethernet interface card) stops blinking and the flash utility begins flashing the application file to the Ethernet interface card. Refer to Table 3-1 on page 3-15 for a complete description of the LEDs on the Ethernet interface card.

If an error occurs and the connection to the Ethernet interface card cannot be established, the message shown in Figure 5-8 is displayed.

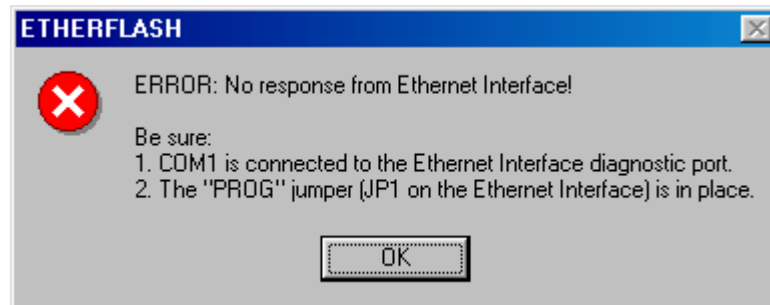

**Figure 5-8. Error Message Displayed when the Attempted Connection Fails**

When you receive this error message, click **OK** and a new window is displayed. See Figure 5-9.



**Figure 5-9. Error Message Following An Unsuccessful Flash Attempt**

When the connection to the Ethernet interface card fails, the flash process also fails. When you receive this message, click **OK** and a new window is displayed. See Figure 5-10.

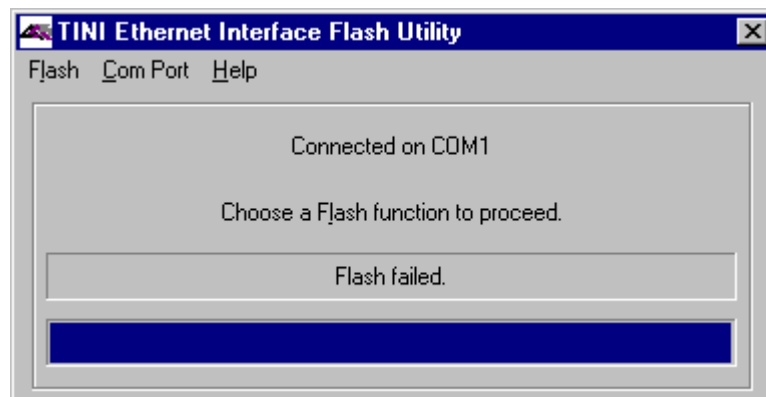

**Figure 5-10. Second Error Message Following An Unsuccessful Flash Attempt**

There are three possible reasons that a flash fails:

- The null modem cable has been inserted into the 9-pin connector (J7) on the Ethernet interface card incorrectly.
- The jumper (J1) labeled 'Prog' on the Ethernet interface card has been installed incorrectly.
- An incorrect cable has been used to connect the laptop to the Ethernet interface card. You must use the *GSE tech-motive tool* null modem cable (part number 41-41-0109FN).

After checking the above points, repeat Steps 9, 10 and 11 until the error messages fail to appear and the TINI Ethernet Flash Utility begins flashing the application file to the Ethernet interface card.

*NOTE: If you cannot successfully flash the Ethernet interface card from your laptop computer, consult a GSE tech-motive tool engineer.*

**12. Confirm or change the IP address, subnet mask and default gateway.**

When the application file is flashed to the Ethernet interface card, the Application Settings window is displayed. This window allows you to confirm or change the IP address, subnet mask and default gateway being used. See Figure 5-11.

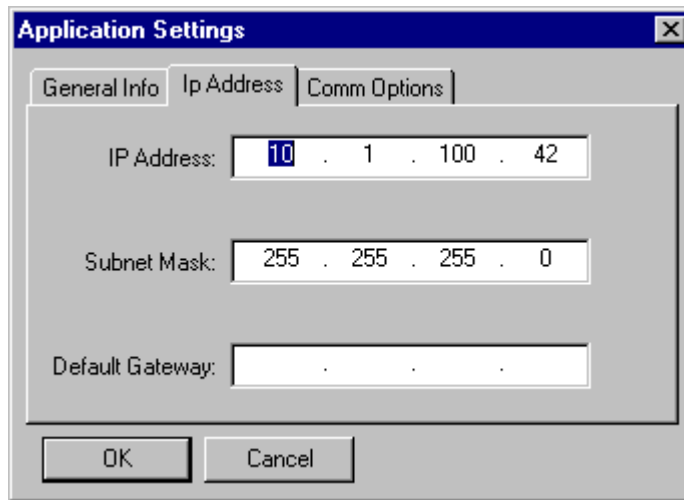

**Figure 5-11. Confirming the IP Address, Subnet Mask and Default Gateway**

To confirm the current settings for the IP address, subnet mask and the default gateway, click **OK**.

**OR**

To change the IP address, subnet mask and/or the default gateway being used:

- a. Click on the **IP Address:**, **Subnet Mask:**, or **Default Gateway:** field.
- b. Enter the new value.
- c. Repeat Steps a) and b) for all the fields you want to change.
- d. Click **OK**.

**13. When the flash utility has finished flashing the application settings to the Ethernet interface card, you can exit.**

*NOTE: If you have another Ethernet interface card to flash, disconnect the cables from the current Ethernet interface card and connect them to the next Ethernet interface card you want to flash. There is no need to exit the TINI Ethernet Flash Utility first.*

The COM port that you opened in Step 9 closes automatically when you exit the flash utility.

- a. Click the **F**lash menu in the TINI Ethernet Flash Utility window.
- b. From the F\ash menu, select **E**xit.

The flash utility closes down and exits you from the program.

**OR**

The flash utility shuts down its connection to the COM port but remains open on the desktop.

- a. Click the **F**lash menu in the TINI Ethernet Flash Utility window.
- b. From the F\ash menu, select **C**om Port.
- c. From the Com Port menu, select **C**lose COM Port.

**14. Close the CS4000 Mini Controller with Ethernet enclosure door.**

**15. Turn OFF power to the controller.**

**16. By hand, install the access screws back into place in the enclosure door, turning them clockwise to tighten them. Finish tightening each access screw with a No.2 cross-tip (Phillips) head screwdriver until each screw is secure.**

**17. Turn ON power to the controller.**

## Updating Application Settings

After you have flashed an application file to the Ethernet interface card, you may want to update settings without re-flashing the entire application file again. To do this, the TINI Ethernet Flash Utility has a menu option that allows you to update the IP address, subnet mask and default gateway values, and enable or disable application functions for the Ethernet network and RS-422 link.

Use Procedure 5-2 to edit application settings.

### ***Procedure 5-2. Editing Application Information***

---

1. If necessary, repeat Steps 1 to 9 from Procedure 5-1 on page 5-2 to connect the laptop to the Ethernet interface card inside the controller.
2. Select TINI Application Info....
  - a. Click the **F**lash menu in the TINI Ethernet Flash Utility window.
  - b. From the F~~l~~ash menu, select **S**et TINI Application Info....

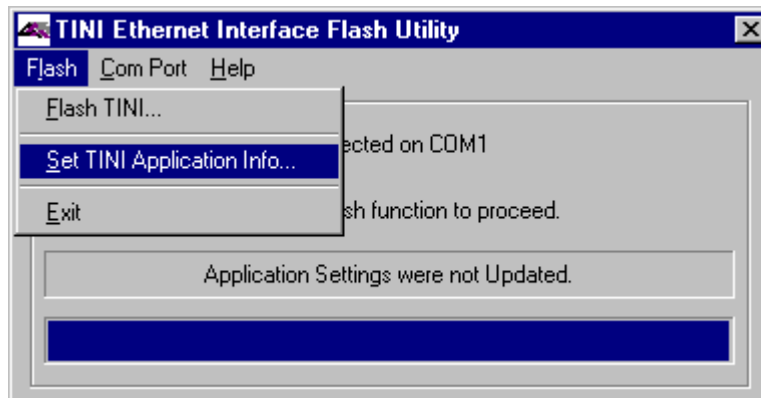

Figure 5-12. Selecting the “**S**et TINI Application Info...” Menu Option

The Application Settings window, shown in Figure 5-13, opens to display the General Info tab. This window shows you details of the last successful flash of an application file to the Ethernet interface card. You cannot change this information; it is automatically updated by the TINI Ethernet Flash Utility whenever a successful flash occurs.

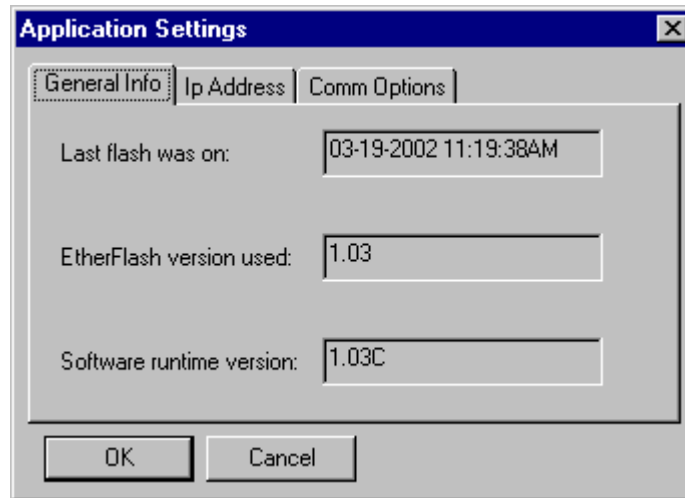

Figure 5-13. Viewing the Application Settings Window - General Info tab

3. Select the Ip Address tab.

- a. From the Application Settings window, click on the **Ip Address** tab. See Figure 5-14.

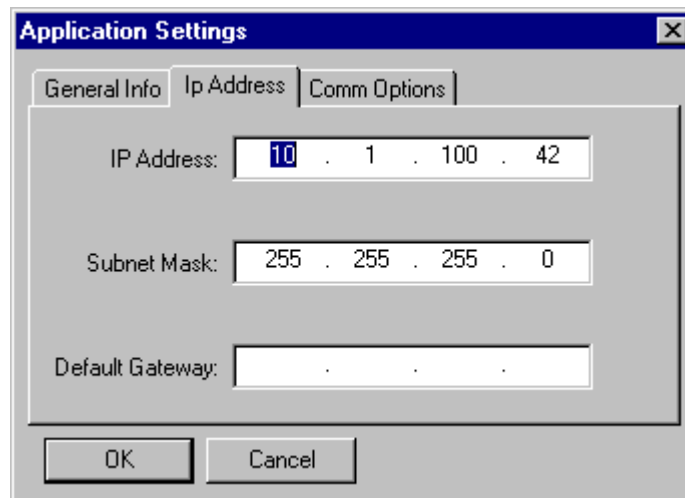

Figure 5-14. Selecting the Application Settings Window - Ip Address tab

4. **To change the IP address, subnet mask and/or default gateway:**
  - a. Click on the **IP Address:**, **Subnet Mask:** or **Default Gateway:** field.
  - b. Enter the new value.
  - c. Repeat Steps a) and b) for all the fields you want to change.
5. **Select the Comm Options tab.**
  - a. From the Application Settings window, click on the **Comm Options** tab. See Figure 5-15.

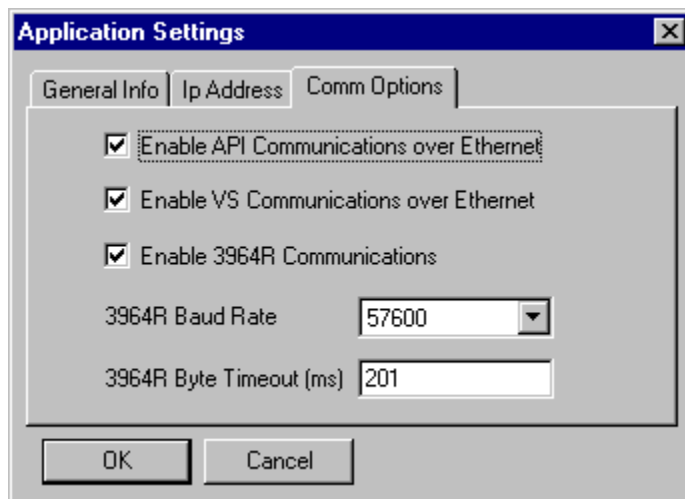

Figure 5-15. Selecting the Application Settings Window - Comm Options tab

*NOTE: When an option is enabled, there is a check mark in the box next to it. When an option is disabled, the box is empty. Click on the box to toggle the option between enabled and disabled.*

6. **To change the communication options:**
  - a. Click on **Enable API Communications over Ethernet** to enable or disable the Application Program Interface (API). When you disable this option, programs cannot request data from the API over the Ethernet.
  - b. Click on **Enable VS Communications over Ethernet** to enable or disable Visual Supervisor communications over the Ethernet. When you disable this option, all Ethernet communications to and from Visual Supervisor are terminated.
  - c. Click on **Enable 3964R Communications** to enable or disable the Siemens 3964R communications protocol used to transfer data to and from the barcode scanner attached to the RS-422 port.

- d. Click on the drop-down menu next to **3964R Baud Rate** to change the baud rate used for communications to and from the barcode scanner attached to the RS-422 port.

You can select from the following baud rates:

- 1200
- 2400
- 4800
- 9600
- 19200
- 38400
- 57600

- e. Click on **3964R Byte Timeout (ms)** and enter the timeout in milliseconds for the barcode scanner attached to the RS-422 port.

**7. To save your changes, click OK.**

The new settings are flashed to the Ethernet interface card.

*NOTE: To flash the new application settings to the Ethernet interface card, make sure you click **OK** before **Cancel**. If you do not click **OK** first, the changes are not flashed to the Ethernet interface card.*

**8. To exit the Application Settings window, click Cancel.**

## Setting Up Visual Supervisor for an Ethernet Network

Install Visual Supervisor on the computer that will be permanently attached to the Ethernet network. During installation of Visual Supervisor on the computer, the installation program will give you the choice to install Visual Supervisor in *permanent* or *portable* mode. You must select *permanent* mode. To find out how to install Visual Supervisor in more detail, refer to the Visual Supervisor User's Guide (part number 39-30-34823).



## Editing VSMain.ini for an Ethernet Network

When you are using the Ethernet link, you must also change *VSMain.ini* manually. In the following example, shown in Figure 5-16, *VSMain.ini* is configured to talk to four Tool Control Modules (TCMs) at IP addresses 10.1.100.167 through 10.1.100.170.

```
[Communications]
Detachable=0
#Ports=4
CommOcx1=Ethernet
CommOcx2=Ethernet
CommOcx3=Ethernet
CommOcx4=Ethernet

[Comm1Devices]
#Devices=1
Device1=DCM
Device1IPAddress=10.1.100.167

[Comm2Devices]
#Devices=1
Device1=DCM
Device1IPAddress=10.1.100.168

[Comm3Devices]
#Devices=1
Device1=DCM
Device1IPAddress=10.1.100.169

[Comm4Devices]
#Devices=1
Device1=DCM
Device1IPAddress=10.1.100.170

[Readings Database]
Enabled=1
ConnectionString=Provider=Microsoft.Jet.OLEDB.4.0;Data
Source=C:\VS\VsDCM Readings.mdb;Persist Security
Info=False
Limit=20000

[Programs To Start]
Program1=VsStart.exe
```

**Figure 5-16. VSMain.ini configured for an Ethernet Network**

*NOTE: For a detailed technical description of each section of VSMain.ini, refer to the Visual Supervisor User's Guide (part number 39-30-34823).*

Use Procedure 5-3 to make the necessary changes to *VSMain.ini*.

### ***Procedure 5-3. Editing VSMain.ini for an Ethernet Network***

1. **Open *VSMain.ini* using Notepad.**
  - a. Click the **Start** menu on the Windows NT desktop.
  - b. From the Start menu, select **P**rograms.
  - c. From the P rograms menu, select **A**ccessories.
  - d. From the Accessories menu, select **N**otepad.
  - e. Click the **F**ile menu in Notepad.
  - f. From the F ile menu, select **O**pen.
  - g. In the file name field enter "C:\Windows\VSMain.ini."
2. **Locate the heading in *VSMain.ini* labeled [Communications] and enter the number of Ethernet connections you need on the network for controllers.**

Your changes to this section of *VSMain.ini* should end up looking similar to this:

```
[Communications]
Detachable=0
#Ports=4
CommOcx1=Ethernet
CommOcx2=Ethernet
.
.
CommOcx4=Ethernet
```

In the above sample, the computer is attached to a network hub to which four devices are connected. Each device requires its own Ethernet communications channel. The number of ports (#Ports=4) refers to the number of controllers that are connected to the network hub.

3. **Locate the heading in *VSMain.ini* labeled [Comm1Devices]. Create an entry for a device that is a controller, specify an IP address for the controller and identify the controller as a Device Control Module (DCM).**

Each device has its own section called [Comm*n*Devices], where *n* is the number of the device or controller in the network. The IP address you enter for the controller is identical to the IP address of the Ethernet motherboard inside the controller. Your changes to this section of *VSMain.ini* should end up looking like this:

```
[Comm1Devices]
#Devices=1
Device1=DCM
Device1IPAddress=[IP address of controller]
```

*NOTE: Enter the IP address in a decimal dot address format. Refer to Working with IP Address, Subnet Mask and Default Gateways earlier in this chapter for details.*

**4. Repeat Step 3 for each controller you are connecting to the Ethernet network.**

Each device has its own section in *VSMMain.ini*. The sample below shows settings for the second controller added to *VSMMain.ini*.

```
[Comm2Devices]
#Devices=1
Device1=DCM
Device1IPAddress=[IP address of the controller]
```

**5. When you are finished editing *VSMMain.ini*, save your changes and exit Notepad.**

- a. Click the **F**ile menu in Notepad.
- b. From the **F**ile menu, select **S**ave.
- c. From the **F**ile menu, select **E**xit.

*VSMMain.ini* is now ready to support an Ethernet network. The new settings take effect the next time you start Visual Supervisor.

## Using Ethernet Network Cables

The type of Ethernet cable you need to connect the CS4000 Mini Controller with Ethernet to the Local Area Network (LAN) is known as 10Base-T. The name is an Institute of Electrical and Electronics Engineers (IEEE) standard identifier for this type of cable. The “10” refers to the transmission speed of 10 million bits per second (Mbps). The “Base” refers to baseband signaling which means only Ethernet signals are carried on this cable and the “T” represents twisted-pair.

When you look at an Ethernet cable, you see four pairs of wires, each pair twisted together into a double helix formation. This is how the cable receives its designation as a twisted-pair. The twisted pair cabling combats interference and helps keep the integrity of signals sent down the cable. The double helix configuration produced by twisting the wires together creates symmetrical noise signals in each wire that cancel each other out, thus reducing the noise level and interference of the signal to a minimum.

**CAUTION!** *It is extremely important to maintain the twisted wires of the Ethernet cable to within half an inch or less of their termination point.*

Table 5-1 shows the pinout used for the RJ-45 modular jack attached to both ends of the 10Base-T cable that connects the controller to the network hub. It uses the IEEE T-568B standard wiring system.

**Table 5-1. Ethernet RJ-45 Modular Jack Pinout**

Pin Designation	Wire Color (Ref)	Twisted Pair	Function
1	WHT/ORN	2	TX+
2	ORN	2	TX-
3	WHT/GRN	3	RX+
4	BLU	1	Unused
5	WHT/BLU	1	Unused
6	GRN	3	RX-
7	WHT/BRN	4	Unused
8	BRN	4	Unused

Ethernet cables are inserted into the Ethernet connector on the bottom panel of each CS4000 Mini Controller with Ethernet. The other end of the Ethernet cable is connected to a network hub. To connect the computer running Visual Supervisor to the network, insert one end of an Ethernet cable into the RJ-45 socket on the computer and the other end into the same network hub that the controllers are attached to. See Figure 1-1 on page 1-3 for a diagram showing the network connections.

## Testing the Ethernet Network

If a computer and/or the controllers connected to each other via the Ethernet network become unable to communicate with each other, you can test the network using a command called *ping*. This command is available on all computers and on the Ethernet interface card.

*NOTE: To use the ping command, TCP/IP must be installed on the Windows operating system of your computer. If the ping command is unavailable, see your System Administrator.*

If parts of the network become unable to communicate you can *ping* a controller and/or computer on the network, from a different controller or computer also on the network, to determine if there are any physical malfunctions such as a bad cable connection. A successful *ping* indicates that the physical network is functioning correctly and it is, therefore, likely that a software malfunction is causing the communication problem. An unsuccessful *ping* indicates that the physical network is not functioning correctly. In this case, you should check the network connections and test the Ethernet cables to find the source of the problem. Refer to the *Testing Ethernet Network Cables* section later in this chapter.

You can test the network, using the *ping* command from the computer permanently attached to it, or you can use a laptop computer temporarily attached to an Ethernet interface card inside a controller on the network. If you are using a laptop computer, you must make sure that it is attached to the Ethernet interface card correctly. To do this, follow Steps 1 to 5 of Procedure 5-1 on page 5-2.

To use the *ping* command from a laptop computer attached to the Ethernet network, you can set up a Hyperterminal connection. Use Procedure 5-4 to set up Hyperterminal so you can *ping* the network from a laptop computer and use Procedure 5-5 to *ping* the network from the host computer.

### **Procedure 5-4. Testing the Network From A Laptop Computer**

---

**CAUTION!** Before you carry out this procedure, make sure jumper, J1, labeled 'Prog' on the Ethernet interface card is pulled off pins 1 and 2.

#### **1. Open Windows Explorer on the Windows desktop.**

*NOTE: Different versions of the Windows operating system may have a different menu structure. Refer to the on-line help supplied with the Windows operating system.*

- a. Click the **Start** menu on the Windows desktop.
- b. From the Start menu, select **Programs**.
- c. From the **Programs** menu, select **Accessories**.
- d. From the Accessories menu, select **Communication**.
- e. From the Communication menu, select **Hyperterminal**.
- f. Click **Hyperterminal**.

2. Enter a name to identify this connection and select the Hyperterminal icon you want to use for it. See Figure 5-17.
  - a. Enter a meaningful name for the Hyperterminal connection in the **Name:** field.
  - b. Select the shortcut **Icon:** for the Hyperterminal connection and click on it.
  - c. Click **OK**.



**Figure 5-17. Select the Icon and Enter A Name for the Hyperterminal Connection**

*NOTE: When you next want to use this connection all you need to do is look for the shortcut icon under the Hyperterminal menu and then click on it.*

3. **Select the communications port you want to use for the Hyperterminal connection. See Figure 5-18.**

This is the communications port to which the null modem cable is attached. Usually COM1 is the communications port selection but you may choose any communications port on the computer.



Figure 5-18. Select Communications Port

4. **Specify the communications port settings. See Figure 5-19.**

- a. Set the **Bits per second:** field to 115200.
- b. Set the **Data bits:** field to 8.
- c. Set the **Parity:** field to None.
- d. Set the **Stop bits:** field to 1.
- e. Set the **Flow Control:** field to Hardware.
- f. Click **OK**.

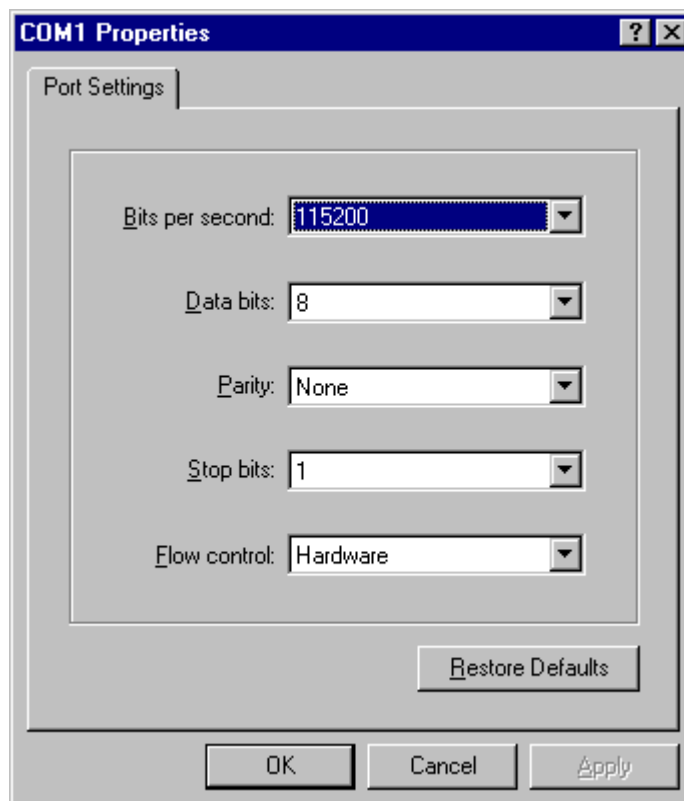

**Figure 5-19. Setting the Communications Port Settings**

When you click **OK**, Hyperterminal attempts to make a connection with the attached Ethernet interface card.

5. Hit the ENTER key on the computer keyboard to view the login prompt: 'TINI login.' See Figure 5-20.

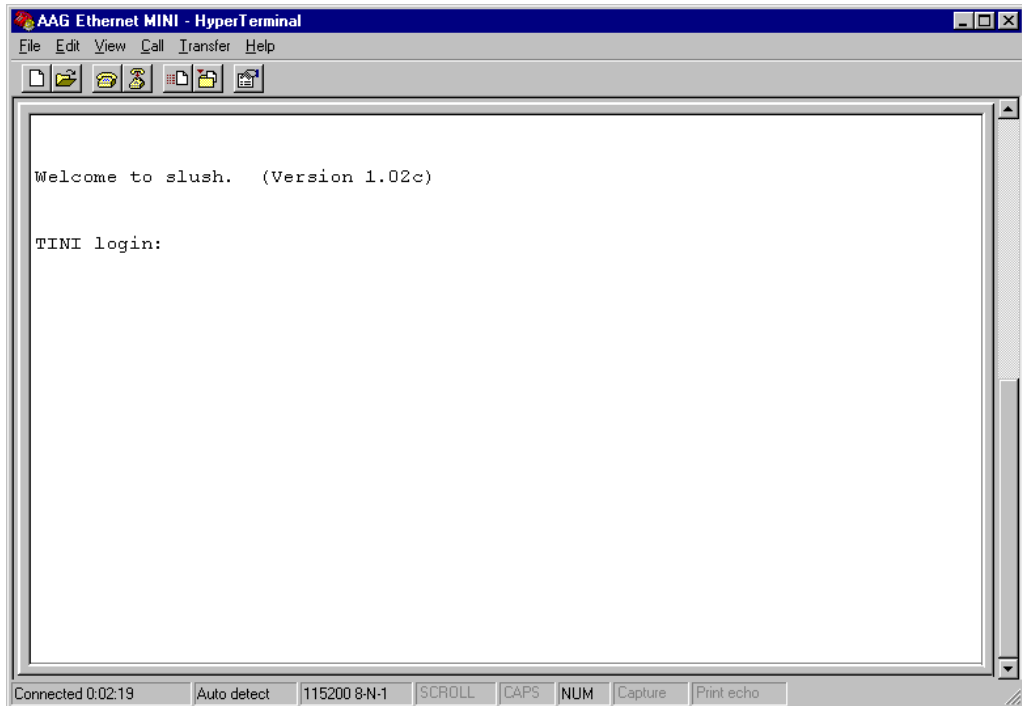

**Figure 5-20. Hyperterminal Window Showing Ethernet Interface Card (TINI) Login Prompt**

*NOTE: If the Hyperterminal window does not appear when you hit the ENTER key, make sure the jumper, J1, labeled "Prog" on the Ethernet interface card is removed.*

You are now ready to log on to the Ethernet network, via the Ethernet interface card.

6. **Login to the attached Ethernet interface card.**
  - a. At the TINI Login: prompt, enter 'root.'
  - b. At the Password: prompt, enter 'tini.'



**7. Enter *ping* followed by the IP address of the computer or controller on the Ethernet network that you want to test.**

*NOTE: The IP address of the Ethernet interface card is the same as the IP address of the computer or controller to which it is attached.*

For example, if the IP address of another controller in the Ethernet network is '10.1.100.177' then you would enter 'ping 10.1.100.177' and would look like this:

```
TINI/> ping 10.1.100.177
```

If *ping* is successful, you see a message in the Hyperterminal window similar to:

```
Got a reply from node 10.1.100.177/10.1.100.177  
Sent 1 request(s), got 1 reply(s)
```

```
TINI/>
```

If *ping* is unsuccessful, you see a message returned in the Hyperterminal window similar to:

```
Node 10.1.100.177/10.1.100.177 was unreachable  
Sent 1 request(s), got 0 reply(s)
```

```
TINI/>
```

**8. Repeat Step 7 for every IP address that you want to test.**

**9. When you are finished testing the network, logout of Hyperterminal.**

- a. At the TINI prompt, enter 'logout.'

The Hyperterminal session ends and returns you to the Windows desktop.

When the *ping* command is successfully applied to the IP addresses you are testing, you know the physical network connections are working correctly. If you still have a network problem, it is likely to be the result of a software malfunction.

*NOTE: As well as the ping command described in Procedure 5-4, there are a number of other commands available, such as ipconfig and tcm. These commands can also be used to diagnose problems with an Ethernet network. Consult a GSE tech-motive tool engineer for details.*

Use Procedure 5-5 to test the Ethernet network from the host computer.

*NOTE: There is an alternative to the method described in Procedure 5-5. You can use the Telnet application, if it is installed on the Windows operating system of the host computer. Telnet establishes a connection across the Ethernet network to the Ethernet interface card in any controller. Telnet logs on to the network using the IP address of the controller. Once logged in, you can use the ping command to test the network connection, refer to Procedure 5-4 from Step 6 onward. To find out more about using Telnet, see your System Administrator.*

### **Procedure 5-5. Testing the Network From A Host Computer**

#### **1. Open Windows Explorer on the Windows desktop.**

*NOTE: Different versions of the Windows operating system may have a different menu structure. Refer to the on-line help supplied with the Windows operating system.*

- a. Click the **Start** menu on the Windows desktop.
- b. From the Start menu, select **P**rograms.
- c. From the **P**rograms menu, select **MS-DOS Prompt**.

A command prompt window opens using MS-DOS, shown in Figure 5-21. You are now ready to begin testing the Ethernet network.

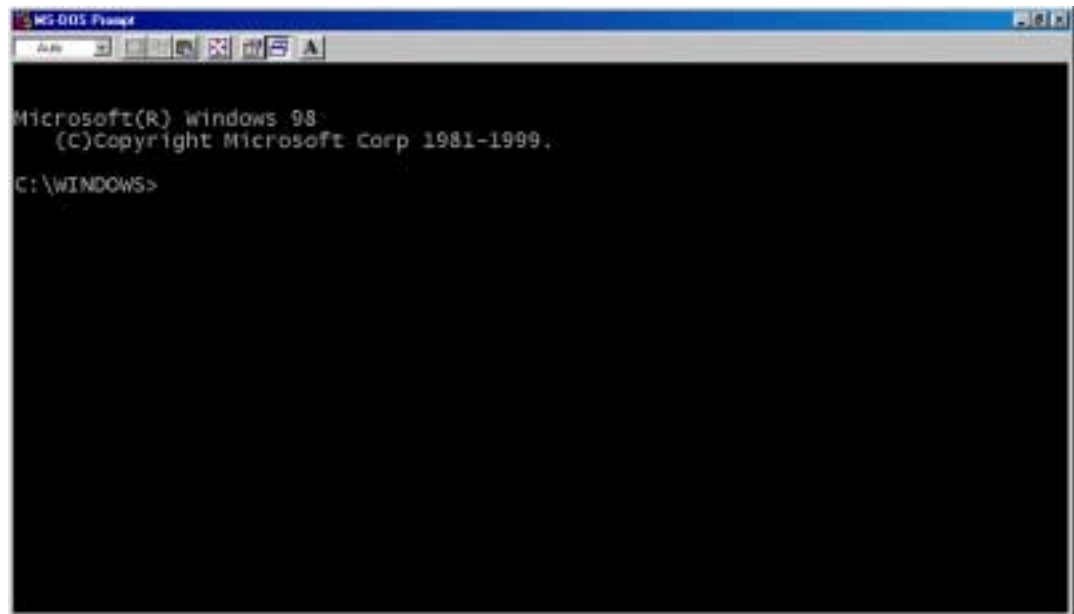

Figure 5-21. Opening the Command Prompt Window

2. Enter *ping* followed by the IP address of the computer or controller on the Ethernet network that you want to test.

*NOTE: The IP address of the Ethernet interface card is the same as the IP address of the computer or controller to which it is attached.*

For example, if the IP address of another controller in the Ethernet network is '10.1.100.177' then you would enter 'ping 10.1.100.177.' It looks like this:

```
c:\> ping 10.1.100.177
```

If *ping* is successful, you see a message returned in the command prompt window similar to:

```
Pinging 10.1.100.177 with 32 bytes of data:
Reply from 10.1.100.177: bytes=32 time=10ms TTL=255
Reply from 10.1.100.177: bytes=32 time=10ms TTL=255
Reply from 10.1.100.177: bytes=32 time=10ms TTL=255
Reply from 10.1.100.177: bytes=32 time=10ms TTL=255
c:\>
```

If *ping* is unsuccessful, you see a message returned in the command prompt window similar to:

```
Pinging 10.1.100.177 with 32 bytes of data:
Request timed out.
Request timed out.
Request timed out.
Request timed out.
c:\>
```

3. Repeat Step 2 for every IP address you want to test.
4. When you are finished testing the network, exit the command prompt window.
  - a. At the C:\ prompt, enter exit.

The command prompt window closes and returns you to the Windows desktop.

When the *ping* command is successfully applied to the IP addresses you are testing, you know that the physical network connections are working correctly. If you still have a network problem, it is likely to be the result of a software malfunction.

*NOTE: As well as the ping command described in Procedure 5-5, there are a number of other commands available, such as ipconfig and tcm. These commands can also be used to diagnose problems with an Ethernet network. Consult a GSE tech-motive tool engineer for details.*

## Testing Ethernet Network Cables

It is important to test Ethernet cables, whether you make them yourself or use ready-made cables. By doing this, you make sure that they are in working order. It is recommended that you test cables using a Remote Network Cable Tester that you can obtain from a computer networking retailer of your choice.

# 6. Setting Up the 485 Network

The CS4000 Mini Controller with Ethernet can be connected to a Local Area Network (LAN) using a 485 network link and a special Synchronous Data Link Control (SDLC) card. This chapter describes the steps you must take to set up the LAN:

- Installing the SDLC card in the computer you want attached to the network.
- Setting up Visual Supervisor for networks.
- Assigning a network address for each controller.
- Setting up cables for the network.

## Installing the SDLC Card

The SDLC card is 'plug and play.' It is installed using the Peripheral Component Interconnect (PCI) system and PCI slot on your computer. Installing the SDLC card forms a connection between the microprocessor in the computer and any attached devices. In this case, you are attaching controllers as devices. You will find a PCI slot on most computers. If you cannot find the PCI slot on your computer, refer to the manual that came with it.

Make sure your computer is switched off then insert the SDLC card into the PCI slot. To install the SDLC card on your system, start the computer and follow the instructions given to you by the Windows NT Operating System. No further programming for the SDLC card is required.

## Setting Up Visual Supervisor for a 485 Network

Install Visual Supervisor on your computer. During installation of Visual Supervisor on the computer, the installation program will give you the choice to install Visual Supervisor in *permanent* or *portable* mode. You must select *permanent* mode. To find out how to install Visual Supervisor in more detail, refer to the Visual Supervisor User's Guide (part number 39-30-34823).

## Editing VSMain.ini for a 485 Network

When you are using a 485 network, you must also change *VSMain.ini* manually. In the following example, shown in Figure 6-1, *VSMain.ini* is configured to talk to four TCMs using a single SDLC channel.

```
[Communications]
Detachable=0
CommOcx1=Sdlc
#Ports=1

[Comm1Devices]
#Devices=4
Device1=DCM
Device2=DCM
Device3=DCM
Device4=DCM

[CommOcx1]
SDLCAdapterType=ESCCP
SDLCBitRateIndex=4

[Readings Database]
Enabled=1
ConnectionString=Provider=Microsoft.Jet.OLEDB.4.0;Data
Source=C:\VS\VsDCM Readings.mdb;Persist Security
Info=False
Limit=20000

[Programs To Start]
Program1=VsStart.exe
```

**Figure 6-1. VSMain.ini configured for a 485 Network**

*NOTE: For a detailed technical description of each section of VSMain.ini, refer to the Visual Supervisor User's Guide (part number 39-30-34823).*

Use Procedure 6-1 to make the necessary changes to *VSMain.ini*.

### ***Procedure 6-1. Editing VSMain.ini for a 485 Network***

---

**1. Open *VSMain.ini* using Notepad.**

- a. Click the **Start** menu on the Windows NT desktop.
- b. From the Start menu, select **P**rograms.
- c. From the P rograms menu, select **A**ccessories.
- d. From the Accessories menu, select **N**otepad.
- e. Click the **F**ile menu in Notepad.
- f. From the F ile menu, select **O**pen.
- g. In the file name field enter "C:\Windows\VSMain.ini."

**2. Locate the heading in *VSMain.ini* labeled [Communications] and enter a single port for an SDLC channel.**

Typically, a 485 network only has a single SDLC channel to which all the controllers are connected. Your changes to this section of *VSMain.ini* should end up looking similar to this:

```
[Communications]
Detachable=0
#Ports=1
CommOcx1=SDLC
```

In the above sample, the network consists of a single SDLC channel to which all the computer and controllers are connected.

**3. Locate the heading in *VSMain.ini* labeled [Comm1Devices]. Create an entry for a device that is a controller, and identify the controller as a Device Control Module (DCM).**

Each device is labeled as 'Device1,' 'Device2,' and so on. 'Device1' is the first controller on the network, 'Device2' is the second controller on the network until the list finishes with the last controller on the network. Your changes to this section of *VSMain.ini* should end up looking similar to this:

```
[Comm1Devices]
#Devices=4
Device1=DCM
Device2=DCM
Device3=DCM
Device4=DCM
```

In the above sample, there are four devices connected to the network and each one is a DCM.

4. When you are finished editing *VSMain.ini*, save your changes and exit Notepad.
  - a. Click the **F**ile menu in Notepad.
  - b. From the **F**ile menu, select **S**ave.
  - c. From the **F**ile menu, select **E**xit.

*VSMain.ini* is now ready to support a 485 network. The new settings take effect the next time you start Visual Supervisor.

## Assigning A Network Address

Each controller attached to the 485 network requires its own address. If you have a computer attached to four controllers, you have a total of five devices attached to the 485 network and each one needs its own address.

Network addresses for a 485 network link are set using the address switch, SW-1, found on the backplane of each Tool Control Module (TCM) inside the controller enclosure. See Figure 3-8 on page 3-11 for the position of the address switch, SW-1. The address switch consists of eight DIP switches. Each DIP switch is set in binary as ON or OFF. The ON binary values for switch positions 1, 2, 3, 4, 5, and 6 are 1, 2, 4, 8, 16, 32, respectively.

**Table 6-1. Switch Positions Representing Binary Numbers**

Switch	Binary Number
1	1
2	2
3	4
4	8
5	16
6	32

*NOTE: Switches 7 and 8 are not used to set the address.*

The address number you assign is equal to the total value of all the switch positions that you set to ON. Table 6-2 shows you how to set the first 32 addresses on the network.

**Table 6-2. Setting Address Switches**

To set the following address number:	Set these Address switches ON:	Keep these DIP switches OFF
Address 1	1	2, 3, 4, 5, 6, 7, 8
Address 2	2	1, 3, 4, 5, 6, 7, 8
Address 3	1, 2	3, 4, 5, 6, 7, 8
Address 4	3	1, 2, 4, 5, 6, 7, 8
Address 5	1, 3	2, 4, 5, 6, 7, 8
Address 6	2, 3	1, 4, 5, 6, 7, 8

Table 6-2. Setting Address Switches (continued)

To set the following address number:	Set these Address switches ON:	Keep these DIP switches OFF
Address 7	1, 2, 3	4, 5, 6, 7, 8
Address 8	4	1, 2, 3, 5, 6, 7, 8
Address 9	1, 4	2, 3, 5, 6, 7, 8
Address 10	2, 4	1, 3, 5, 6, 7, 8
Address 11	1, 2, 4	3, 5, 6, 7, 8
Address 12	3, 4	1, 2, 5, 6, 7, 8
Address 13	1, 3, 4	2, 5, 6, 7, 8
Address 14	2, 3, 4	1, 5, 6, 7, 8
Address 15	1, 2, 3, 4	5, 6, 7, 8
Address 16	5	1, 2, 3, 4, 6, 7, 8
Address 17	1, 5	2, 3, 4, 6, 7, 8
Address 18	2, 5	1, 3, 4, 6, 7, 8
Address 19	1, 2, 5	3, 4, 6, 7, 8
Address 20	3, 5	1, 2, 4, 6, 7, 8
Address 21	1, 3, 5	2, 4, 6, 7, 8
Address 22	2, 3, 5	1, 4, 6, 7, 8
Address 23	1, 2, 3, 5	4, 6, 7, 8
Address 24	4, 5	1, 2, 3, 6, 7, 8
Address 25	1, 4, 5	2, 3, 6, 7, 8
Address 26	2, 4, 5	1, 3, 6, 7, 8
Address 27	1, 2, 4, 5	3, 6, 7, 8
Address 28	3, 4, 5	1, 2, 6, 7, 8
Address 29	1, 3, 4, 5	2, 6, 7, 8
Address 30	2, 3, 4, 5	1, 6, 7, 8
Address 31	1, 2, 3, 4, 5	6, 7, 8
Address 32	6	

Using the information in Table 6-2, Figure 6-2 shows you how to set address '5.'

	1	2	3	4	5	6	7	8
ON	■		■					
↑		■		■	■	■	■	■

Figure 6-2. Network Address DIP Switch Set for Address '5'



Use Procedure 6-2 to set the address on the backplane of the controller.

### ***Procedure 6-2. Setting the Address for the Controller***

---

1. Turn OFF power to the controller.

***WARNING! Make sure the power is OFF before you remove the TCM. High voltage when the power is ON can result in electrical shock or electrocution, and also damage to the TCM.***

2. Using a No.2 cross-tip (Phillips) head screwdriver, turn the access screws on the outside of the enclosure counterclockwise to loosen them. Finish removing them by hand.
3. Open the enclosure door and locate the Tool Control Module (TCM).
4. Locate the TCM and the two thumbscrews that fasten the TCM to the backplane. The screws are located on the upper right and lower left corners of the TCM.
5. Turn the two thumbscrews counterclockwise to loosen them and carefully remove them, placing them somewhere safe until you need them again.
6. Pull the TCM from the top edge, rocking it gently to loosen it from the backplane.
7. Remove the TCM and place it in a safe location, such as on a work table.
8. **Locate the address switch, SW-1, for the network address.**  
See Figure 3-8 on page 3-11 for the position of the address switch, SW-1, on the TCM backplane from which the TCM was removed.
9. **Make sure the switch is set properly.**  
The address can be any consecutive number 1 through 32.
10. **Install the TCM, using the positioning pins on the upper left corner and middle right of the backplane to position the TCM on the backplane.**
11. **Press the TCM gently, but firmly, back into place in the controller enclosure.**
12. **By hand, install the access screws back into place in the enclosure door, turning them clockwise to tighten them. Finish tightening each access screw with a No. 2 cross-tip (Phillips) head screwdriver until each screw is secure.**
13. **Close the enclosure door on the controller.**
14. **Using a No.2 cross-tip (Phillips) head screwdriver, turn the locknuts on the outside of the enclosure clockwise to tighten them.**
15. **Turn ON power to the controller enclosure.**
16. **Repeat Steps 1 through 15 for each controller, setting the address switch to a different address each time.**

## Using 485 Network Cables

The type of cable you need to connect the CS4000 Mini Controller with Ethernet to the LAN using the 485-link is the Bellden 8104 low capacitance computer cable or equivalent.

The computer and controllers form a *daisy chain* when they are networked together, see Figure 1-2 on page 1-5. The cable is inserted in the RS-485 port on the bottom panel of the controller and either inserted into the RS-485 port controller next to it in the network, or, if it is the first controller in the network, to the RS-485 port of the supervising computer.

(This page is left blank intentionally.)

# 7. Setting Up the RS-232 Link

The CS4000 Mini Controller with Ethernet can be connected to a laptop computer and serve a stand-alone unit. This chapter describes the steps you must take to create this connection:

- Setting up Visual Supervisor for a stand-alone controller
- Using RS-232 cables

## Setting Up Visual Supervisor

Install Visual Supervisor on the laptop computer that will be attached to the CS4000 Mini Controller. During installation of Visual Supervisor on the computer, the installation program will give you the choice to install Visual Supervisor in *permanent* or *portable* mode. You must select *portable* mode. To find out details describing how to install Visual Supervisor, refer to the Visual Supervisor User's Guide (part number 39-30-34823). There is no requirement to edit *VSMain.ini*.

## Using RS-232 Cables

The type of cable used to connect the laptop computer to the controller is known as a null modem cable (part number 41-41-0109FN). To attach the laptop computer to the controller, insert the RS-232 cable into the RS-232 port on the bottom panel of the controller and insert the other end into the RS-232 compatible port on the laptop.

(This page is left blank intentionally.)

# 8. Maintenance/Troubleshooting

Maintenance of the CS4000 Mini Controller with Ethernet consists of replacing fuses and cleaning the enclosure window. The Troubleshooting section of this chapter gives possible solutions to problems and describes how to locate a malfunction in the Ethernet network.

## Replacement Parts

If, at any time, you need to replace or order new parts for your CS4000 Mini Controller with Ethernet you can select from any item in Table 8-1.

**Table 8-1. Replacement Parts**

Quantity	Description	Part Number
1	27A Tool Control Module (TCM)	49-4100-03C5
1	8A Tool Control Module (TCM)	49-4100-01CL5
1	+24V DC Power Supply	12-20-5007
1	Ethernet Interface Card	420959-38093
1	Fuse 1ASB, Littelfuse 39001 5x20 mm	13-10-61001
2	Fuse .5pico, Littelfuse 255.500	13-10-4050
1	Limit Selector Switch	Amp Part Number 436037-1 16-30-0940
1	Backplane	420890-35327
1	I/O Connector Module Assembly	244000-38183
1	Interbus-S Module	Weiland Part Number 83.031.1300.1 41-30-0300

*NOTE: All part numbers used in Table 8-1 are GSE tech-motive tool part numbers unless otherwise specified.*

## Replacing Main Power Fuses

### Main Power

**F1 and F2** = 15A, 250V, SLO-BLO  
Littelfuse 313015 or equivalent (part number 13-10-1015)

Refer to Figure 3-3 on page 3-4 to locate the main power fuses on the CS4000 Mini Controller bottom panel.

## Replacing Backplane Fuses

### Backplane

**F2 and F3** = 0.5A, 250V, subminiature PICO  
Littelfuse 255.500 or equivalent (part number 13-10-4050)

*NOTE: The backplane fuse, F2 (part number 13-10-4050), is not the same as the main power fuse, F2 (part number 13-10-1015), refer to Replacing Main Power Fuses above. Make sure you quote the correct part number when ordering replacements.*

**F4** 5x20 mm, 1A, SLO BLO (SB) 250V  
Littelfuse 239001 or equivalent (part number 13-10-61001)

Refer to Figure 3-8 on page 3-11 to locate the backplane fuses.

## Cleaning the Enclosure Window

Use only water-based cleaners to clean the plastic window. Other solvents may damage the window.

## Troubleshooting

This section describes some of the problems you may encounter with the Ethernet network, RS-422 (Siemens 3964R) interface and the Application Program Interface (API), and gives brief descriptions of how you might attempt to solve each problem.

### Ethernet Network

When the Ethernet network needs troubleshooting, you can:

- Refer to *Testing the Ethernet Network* in *Chapter 5. Setting Up the Ethernet* to find out how to use the *ping* command through Hyperterminal or Telnet applications.
- Refer to Table 3-1 on page 3-15 for a list of LEDs that exist on the Ethernet interface card within the CS4000 Mini Controller.
- Use the TINI Ethernet Flash Utility to modify the Ethernet interface card application settings and disable unnecessary functions (the latter may help if the troubleshooting problem is related to thru-put performance.) To find out how to update the application settings, refer to *Updating Application Settings* in *Chapter 5. Setting Up the Ethernet*.

Table 8-2 describes some common problems of the Ethernet network and TINI Ethernet interface card, and gives possible solutions for each problem.

**Table 8-2. Ethernet Common Problems and Solutions**

Problem	Cause	Solution
<b>No communication</b>	<i>VsMain.ini</i> is not in Ethernet mode	Correct <i>VsMain.ini</i> .
	IP address is incorrect.	Check IP address using the TINI Ethernet Interface Flash utility.  If the IP address is incorrect, update or reprogram settings using the TINI Ethernet Interface Flash Utility.  Use the <i>ping</i> command to check new IP address.
	No +24 VDC on Ethernet board.	Check +24 VDC power supply. Check J1 connector is installed.
	Check Ethernet cable.	Replace the cable if it is broken or damaged.
<b>Tool Control Module (TCM) is not communicating with the Ethernet network</b>	Baud rate incorrect; LED7 (F) is not blinking on the TINI Ethernet interface card inside the controller.	Make sure the address switch, SW-1, DIP switch 7 is set to ON for correct 57600 baud rate.
<b>No LEDs are illuminated on the TINI Ethernet Interface card</b>	Blown fuse on the +24 VDC power supply.	Check fuse 3A on the +24 VDC power supply.  Repair or replace +24 VDC power supply.



## RS-422 (Siemens 3964R) Interface

If you encounter problems with the RS-422 (Siemens 3964R) interface, you can use Procedure 5-4 on page 5-17. Although this procedure describes how you test an Ethernet network from a laptop computer, you can use the same steps to test the RS-422 (Siemens 3964R) interface until you reach Step 7. Instead of using the *ping* command, use the *tcm* command. Using the *tcm* command allows you to view information about the status of communications on the RS-422 port during the debugging process. You can also use two other commands called *tcm mask all* and *tcm unmask VIN* to log the RS-422 port activity.

## Application Program Interface (API)

The Application Program Interface (API) is a software application that runs separately but concurrently to Visual Supervisor. It collects data and sends it to another software application.

If you have problems running the API, check the version number of Device Control Module (DCM) software the controller is running. You must have the DCM firmware at version 4.06 or higher to successfully run the API.

In order for the API to collect data, you must set "History=VIN" in *VSMain.ini* on the VS host computer. For further details about *VSMain.ini*, refer to the Visual Supervisor User's Guide (part number 39-30-34823).

# 9. Technical Information

## Assembly Drawing

The wiring diagrams for the CS4000 Mini Controller with Ethernet are shown in Figure 9-1 on page 9-3 and Figure 9-2 on page 9-5.

(This page is left blank intentionally.)

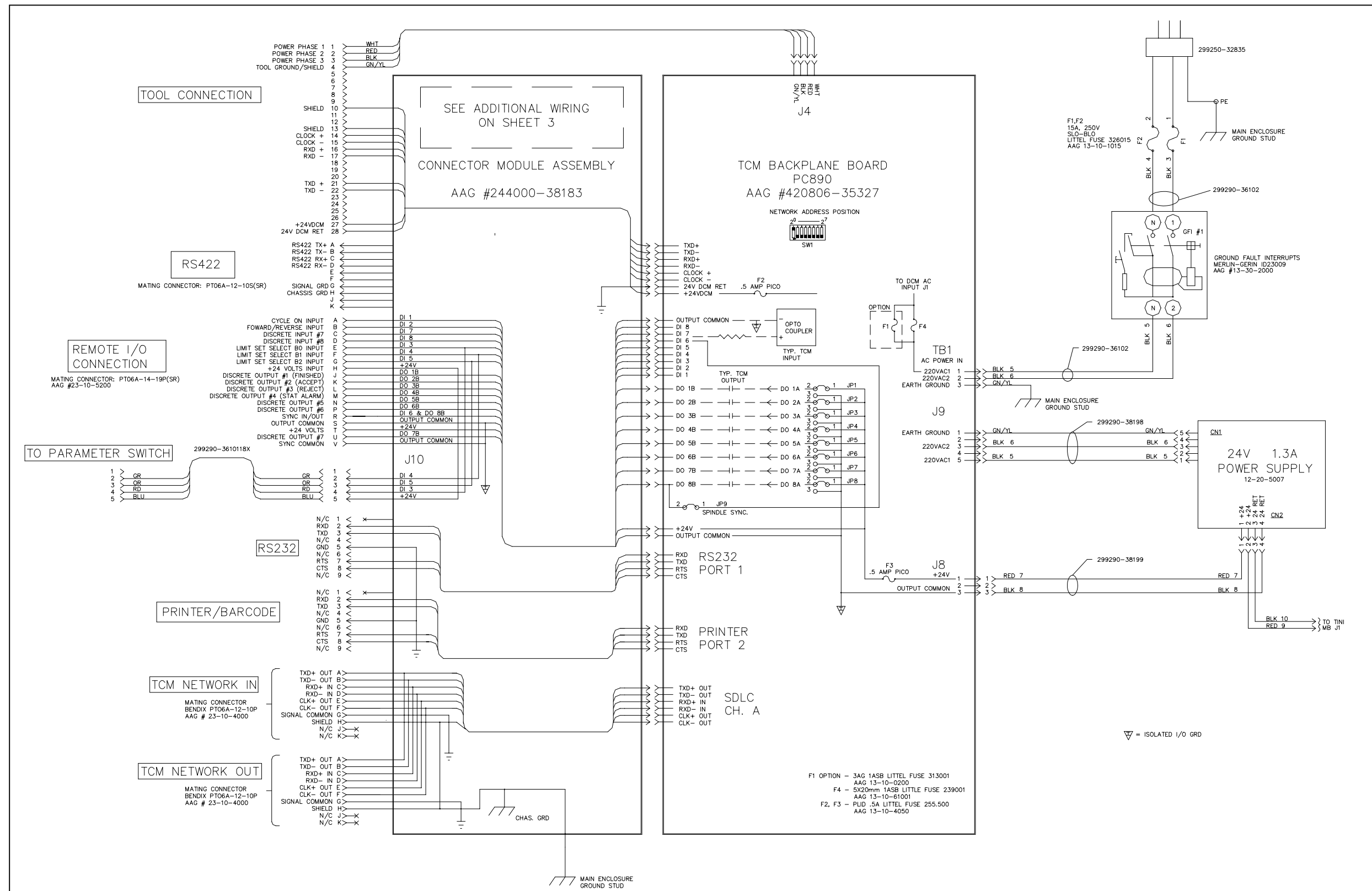

Figure 9-1. CS4000 Mini Controller with Ethernet Wiring of Standard Ethernet and Interbus-S Module

(This page is left blank intentionally.)

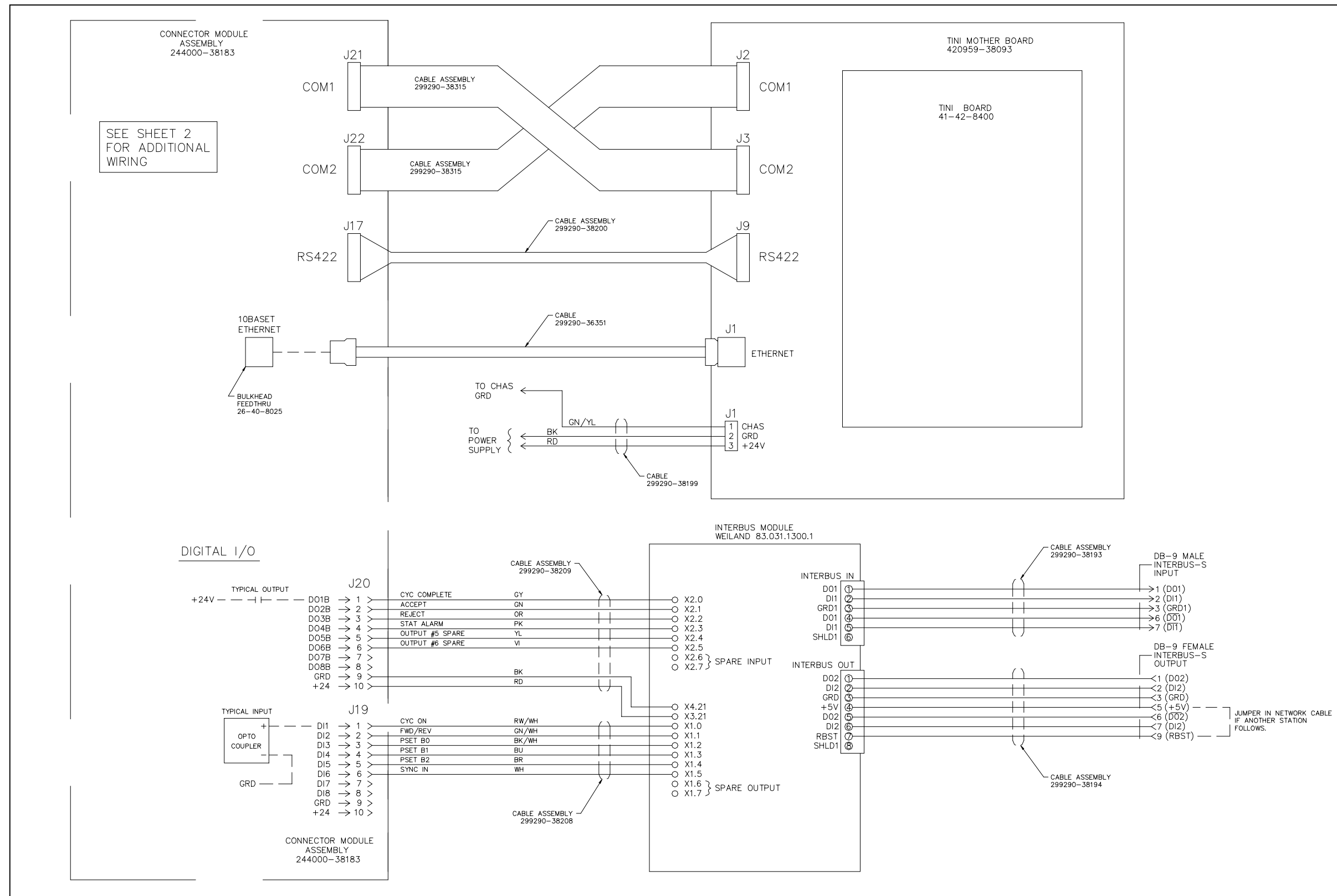

Figure 9-2. CS4000 Mini Controller with Ethernet Wiring of Standard Ethernet

(This page is left blank intentionally.)

# Index

10Base-T, 1-2, 5-16  
485 network cable, 6-7

## A

AC power, 4-4  
AC Power Cord, 3-3  
address switch, 3-6, 6-4  
Address switches, 3-12  
Application Program Interface, 1-2, 8-4

## B

backplane, 3-6, 3-11, 6-4, 8-1  
    Address switches, 3-12  
    DIP switches, 3-12  
    fuse, 3-12, 8-2  
    I/O board, 3-13  
battery, 3-6, 3-10  
baud rate, 3-12

## C

Clear Outputs, 4-5  
communications port, 5-19  
Cycle bad, 4-6  
Cycle Finish, 4-6  
Cycle good, 4-6

## D

daisy chain, 6-7  
DCM, 3-9  
default gateway, 5-1  
Device Control Module, 3-6, 3-10  
    battery, 3-6, 3-10  
digital I/O, 1-2, 1-6, 3-16  
DIP switches, 3-12  
disconnect switch, 2-3  
Dual Power Supply, 3-13  
dual-purpose input, 4-5

## E

electrical drawings, 2-4  
electrical fires, 2-4  
electrical hazards, 2-3  
electrical wiring, 2-4  
enclosure  
    components, 3-7  
    interior, 3-1  
    window, 8-2

Etherflash.exe, 5-3  
Ethernet, 1-7  
Ethernet cable, 1-2, 5-1, 5-16  
    testing, 5-24  
    twisted-pair, 5-16  
Ethernet Connector, 3-5  
Ethernet Flash Utility, 5-2, 5-10  
Ethernet interface card, 1-1, 3-6, 3-13–3-14, 5-1, 8-1  
    initialization, 3-15  
    sub-components, 3-14  
Ethernet Interface Flash Utility, 5-1, 5-3, 5-5  
extinguishers, 2-4

## F

fastening control system, 1-1  
Front Panel, 3-1  
fuse, 2-3, 3-6, 8-1  
    pullers, 2-3  
    substitutes, 2-3  
fuses, 3-6

## G

gateway, 5-1  
ground fault circuit interrupt, 1-1  
Ground Fault Circuit Interrupter, 3-5–3-6, 3-18

## H

Hyperterminal, 5-17

## I

I/O  
    cable, 4-1  
    Connector Module Assembly, 8-1  
    Port, 3-4  
    wiring scheme, 4-9–4-10  
I/O board, 3-13  
input  
    active, 4-7  
    inactive, 4-7  
Intelligent Tools, 1-1  
Interbus-S I/O Port, 3-3  
Interbus-S module, 1-2, 3-6, 3-16, 8-1  
Internet Protocol version 4, 5-2  
IP address, 5-1, 5-22, 5-24



## **L**

LED, 3-9, 3-15, 3-17  
LED display, 3-2  
Limit Selector Switch, 8-1  
Local Area Network, 1-1, 1-4, 3-1, 3-5, 5-1, 6-7

## **M**

main power  
  fuse, 3-18, 8-2  
Manual Calibration, 4-5  
multi purpose switch, 4-5

## **N**

network address, 6-4  
nutrunner, 1-1, 4-4–4-5

## **O**

output current, 4-8

## **P**

Parameter Set Switch, 3-3  
parameter sets, 4-6  
ping, 5-17  
pinout, 4-11, 5-16  
Plant Floor Communication System, 3-12  
potentiometer, 3-9  
power supply, 3-6, 3-15, 3-17, 4-3, 4-6, 8-1  
printer cable, 4-1  
Printer/Barcode port, 1-7  
programmable discrete output, 4-7  
Programmable Logic Controller, 1-2, 3-3

## **R**

remote bus, 3-17  
remote input circuit schematic, 4-8  
remote relay output schematic, 4-8  
repairs, 2-3  
RJ-45  
  connector, 1-1  
  modular jack, 5-16  
router software, 5-1

RS-232  
  port, 1-1, 3-5, 5-3  
RS-232 cable, 7-1  
RS-422  
  port, 1-7, 3-5  
RS-485 port, 1-1, 6-7

## **S**

safety  
  electrical, 2-2–2-3  
safety glasses, 2-3  
SDLC I/O Network Connector, 3-5  
servo amplifier, 3-6, 3-10, 3-18  
  fuse, 3-6, 3-10  
servo amplifier boards, 3-9  
servo amplifier fuse, 3-9  
Siemens 3964R barcode protocol, 1-7, 3-15  
spindle, 3-8  
subnet mask, 5-1  
synchronization input/output, 4-7  
synchronization output, 4-7  
Synchronous Data Link Control, 1-1, 1-4

## **T**

T-568B standard wiring system, 5-16  
TCM subcomponents, 3-9  
Telnet, 5-23  
tool cable, 3-5, 4-1  
Tool Connector, 3-4  
Tool Control Module, 3-8, 8-1  
  fuse, 3-6  
Top and Bottom Panel, 3-1  
Transmission Control Protocol/Internet Protocol (TCP/IP), 1-1–1-2, 3-1, 3-5

## **V**

Visual Supervisor, 1-1, 3-15, 7-1  
  network setup, 5-1  
  permanent mode, 5-13  
  portable mode, 1-6  
voltage, 2-3, 4-8  
  input, 4-4  
VSMMain.ini, 5-14, 6-2

**Part Number: 39-30-38324**



*SPX Corporation  
42860 Nine Mile Road  
Novi, MI 48375-4122 USA  
Phone: (248) 596-0600  
Toll free: (800) 795-7875  
Fax: (248) 596-0601  
Website: [www.gsetechmotive.com](http://www.gsetechmotive.com)*